

# ABRASIVES



Brushes . . . . .	298-303
Cartridge Rolls . . . . .	336-337
Cut-Off Wheels . . . . .	324-325
Depressed Center Wheels . . . . .	326-327
Diamond Tools & Wheels . . . . .	319-323
Flap Discs . . . . .	328-329, 339
Flap Wheels . . . . .	333
Grinding Wheels . . . . .	304-316
Honing Tools . . . . .	298
Mounted Points . . . . .	317-318, 341
Non-Woven . . . . .	338-341
PSA Discs . . . . .	331
Quick Change Discs . . . . .	329, 332
Resin Fibre Discs . . . . .	330
Shop Rolls & Sheets . . . . .	334-335

## Flex-Hone® Tools

- Use on valve guides, cam bearing bores, main bearing bores, lifter bores, pneumatic cylinders, engine cylinders, brake cylinders, drums and rotors, hydraulic guides, pumps, and compressors.

- The Flex-Hone® Tool is resilient, flexible honing tool with soft cutting action. It's unique construction allows the abrasive globules or "stones" to float, assuring the tool will be self-centering, self-aligning to the bore and self-compensating for wear.

- The Flex-Hone® Tool removes peaks and other imperfections in cylinder walls, creating a desirable plateaued finish. The result is reduction in localized heat and friction and improved performance.



## Standard Duty Flex-Hones®

- 4mm – 3/16" are 6" OAL
- 5mm – 3" are 8" OAL
- 3-1/4" – 4-5/8" are 13-1/2"

## Silicon Carbide

FLEX-HONE MODEL NO.	BORE SIZE	120 GRIT		180 GRIT		240 GRIT		320 GRIT	
		ORDER NO.	PRICE EACH	ORDER NO.	PRICE EACH	ORDER NO.	PRICE EACH	ORDER NO.	PRICE EACH
BC-4MM	(0.157)	-	-	5690-151	\$19.90	5690-152	\$21.10	5690-153	\$29.90
BC-4.5MM	(0.177)	-	-	5690-171	19.60	5690-172	20.80	5690-173	29.40
BC-3/16"	(4.75MM)	-	-	5690-181	19.90	5690-182	20.50	5690-183	28.90
BC-5MM	(0.197)	5690-190	\$18.70	5690-191	18.70	5690-192	19.80	5690-193	28.00
BC-5.5MM	(0.217)	5690-210	19.00	5690-211	19.00	5690-212	20.10	5690-213	28.50
BC-6.4MM	(0.25)	5690-250	13.00	5690-251	13.00	5690-252	13.80	5690-253	19.50
BC-7MM	(0.276)	5690-270	13.20	5690-271	13.20	5690-272	13.90	5690-273	19.60
BC-8MM	(0.315)	5690-310	13.80	5690-311	13.80	5690-312	14.60	5690-313	20.60
BC-9MM	(0.354)	5690-350	14.30	5690-351	14.30	5690-352	15.20	5690-353	21.50
BC-9.5MM	(0.375)	5690-370	15.80	5690-371	15.80	5690-372	16.80	5690-373	23.80
BC-10MM	(0.394)	5690-390	16.00	5690-391	16.00	5690-392	16.90	5690-393	24.00
BC-11MM	(0.433)	5690-430	16.30	5690-431	16.30	5690-432	17.30	5690-433	24.50
BC-12MM	(0.472)	5690-470	16.70	5690-471	16.70	5690-472	17.70	5690-473	25.00
BC-1/2"	(12.7MM)	5690-500	17.00	5690-501	17.00	5690-502	18.00	5690-503	25.50
BC-14MM	(0.552)	5690-550	17.10	5690-551	17.10	5690-552	18.10	5690-553	25.70
BC-5/8"	(16MM)	5690-620	18.10	5690-621	18.10	5690-622	19.10	5690-623	27.10
BC-18MM	(0.709)	5690-700	18.60	5690-701	18.60	5690-702	19.60	5690-703	27.80
BC-3/4"	(19MM)	5690-750	19.00	5690-751	19.00	5690-752	20.10	5690-753	28.50
BC-20MM	(0.787)	5690-780	19.10	5690-781	19.10	5690-782	20.20	5690-783	28.70
BC-7/8"	(22MM)	5690-870	19.20	5690-871	19.20	5690-872	20.40	5690-873	28.80
BC-15/16"	(23.8MM)	5690-930	19.90	5690-931	19.90	5690-932	21.10	5690-933	29.80
BC-1"	(25.4MM)	5691-000	20.50	5691-001	20.50	5691-002	21.80	5691-003	30.80
BC-1-1/8"	(29MM)	5691-120	21.60	5691-121	21.60	5691-122	22.90	5691-123	32.40
BC-1-1/4"	(31.8MM)	5691-250	23.20	5691-251	23.20	5691-252	24.70	5691-253	34.90
BC1-3/8"	(35MM)	5691-370	23.90	5691-371	23.90	5691-372	25.30	5691-373	35.90
BC-1-1/2"	(38MM)	5691-500	25.70	5691-501	25.70	5691-502	27.20	5691-503	38.40
BC-1-5/8"	(41MM)	5691-620	25.70	5691-621	25.70	5691-622	27.20	5691-623	38.50
BC-1-3/4"	(45MM)	5691-750	26.80	5691-751	26.80	5691-752	28.40	5691-753	40.20
BC-1-7/8"	(48MM)	5691-870	27.30	5691-871	27.30	5691-872	29.00	5691-873	41.00
BC-2"	(51MM)	5692-000	27.80	5692-001	27.80	5692-002	29.50	5692-003	41.70
BC-2-1/8"	(54MM)	5692-120	29.00	5692-121	29.00	5692-122	30.70	5692-123	43.40
BC-2-1/4"	(57MM)	5692-250	30.10	5692-251	30.10	5692-252	31.90	5692-253	45.10
BC-2-3/8"	(60MM)	5692-370	31.30	5692-371	31.30	5692-372	33.10	5692-373	46.90
BC-2-1/2"	(64MM)	5692-500	32.40	5692-501	32.40	5692-502	34.40	5692-503	48.60
BC-2-5/8"	(67MM)	5692-620	34.10	5692-621	34.10	5692-622	36.20	5692-623	51.20
BC-2-3/4"	(70MM)	5692-750	35.80	5692-751	35.80	5692-752	37.90	5692-753	53.70
BC-2-7/8"	(73MM)	5692-870	38.70	5692-871	38.70	5692-872	41.00	5692-873	58.00
BC-3"	(76MM)	5693-000	41.50	5693-001	41.50	5693-002	44.10	5693-003	62.30
GB-3-1/4"	(83MM)	5693-100	47.80	5693-101	47.80	5693-102	50.70	5693-103	71.60
GB-3-1/2"	(89MM)	5693-120	50.90	5693-121	50.90	5693-122	54.00	5693-123	76.40
GB-3-3/4"	(95MM)	5693-140	54.80	5693-141	54.80	5693-142	58.10	5693-143	82.20
GB-4-1/8"	(105MM)	5693-160	58.30	5693-161	58.30	5693-162	61.80	5693-163	87.50
GB-4-5/8"	(118MM)	5693-180	65.00	5693-181	65.00	5693-182	68.90	5693-183	97.50



## Heavy Duty Flex-Hones®

- 3" – 4-1/2" are 13-1/2" OAL
- 5" – 8" are 17-1/2" OAL

FLEX-HONE MODEL NO.	BORE SIZE	120 GRIT		180 GRIT		240 GRIT		320 GRIT	
		ORDER NO.	PRICE EACH	ORDER NO.	PRICE EACH	ORDER NO.	PRICE EACH	ORDER NO.	PRICE EACH
GBD-3"	(76MM)	5693-300	\$69.30	5693-301	\$ 69.30	5693-302	\$ 73.40	5693-303	\$103.90
GBD-3-1/4"	(83MM)	5693-320	71.50	5693-321	71.50	5693-322	75.80	5693-323	107.20
GBD-3-1/2"	(89MM)	5693-340	73.60	5693-341	73.60	5693-342	78.00	5693-343	110.40
GBD-3-3/4"	(95MM)	5693-360	78.90	5693-361	78.90	5693-362	83.70	5693-363	118.40
GBD-4"	(101MM)	5693-380	84.20	5693-381	84.20	5693-382	89.30	5693-383	126.30
GBD-4-1/4"	(108MM)	5693-400	90.00	5693-401	90.00	5693-402	95.40	5693-403	134.40
GBD-4-1/2"	(114MM)	5693-420	95.80	5693-421	95.80	5693-422	101.60	5693-423	143.70
GBD-5"	(127MM)	5693-440	109.00	5693-441	109.00	5693-442	115.60	5693-443	176.40
GBD-5-1/2"	(140MM)	5693-460	119.60	5693-461	119.60	5693-462	126.80	5693-463	193.50
GBD-6"	(152MM)	5693-480	129.60	5693-481	129.60	5693-482	137.30	5693-483	209.60
GBD-6-1/2"	(165MM)	5693-500	139.70	5693-501	139.70	5693-502	148.10	5693-503	225.90
GBD-7"	(178MM)	5693-520	152.30	5693-521	152.30	5693-522	161.40	5693-523	246.40
GBD-7-1/2"	(190MM)	5693-540	167.50	5693-541	167.50	5693-542	177.50	5693-543	270.90
GBD-8"	(203MM)	5693-560	183.00	5693-561	183.00	5693-562	194.10	5693-563	296.20

## Trulock Crimped Wire Wheel Brushes



## Orbitor Bench Grinder Brushes



Features plastic snap-out arbor hole adapter.  
Other arbor hole available on request

DIA.	WIRE SIZE	ARBOR HOLE	TRIM LENGTH	FACE WIDTH	MAX SAFE FREE SPEED (RPM)	STD. PKG.	ITEM NO.	PRICE EACH
<b>Narrow Face</b>								
4	.008	1/2-3/8†	7/8	1/2	6,000	2	6500-104	\$44.45
4	.0095	1/2-3/8†	7/8	1/2	6,000	2	6500-124	24.35
6	.008	5/8-1/2†	1-7/16	3/4	6,000	10	6501-045	36.56
6	.014	5/8-1/2†	1-7/16	3/4	6,000	10	6501-075	26.65
8	.0118	5/8-1/2†	2-1/16	3/4	6,000	2	6501-165	42.00
8	.014	5/8-1/2†	2-1/16	1/2	6,000	2	6501-175	37.13
10	.0118	3/4	2-1/2	3/4	4,000	2	6501-248	55.30
10	.014	3/4	2-1/2	3/4	4,000	2	6501-258	53.10
<b>Medium Face</b>								
6	.0118	2††	1-1/8	1	6,000	1	6506-070	51.24
6	.014	2††	1-1/8	1	6,000	1	6506-080	51.74
8	.0118	2††	1-3/8	1	4,000	1	6506-110	77.81
8	.014	2††	1-3/8	1	4,000	1	6506-120	77.40
10	.0118	2*	2	1-1/8	3,600	1	6506-150	127.86
10	.014	2**	2	1-1/8	3,600	1	6506-160	125.68
<b>Wide Face</b>								
6	.0118	2††	1-1/8	1-1/8	6,000	1	6503-060	78.34
8	.0118	2††	1-3/8	1-3/8	4,000	1	6503-140	120.82
10	.0118	2††	1-7/8	1-5/8	4,000	1	6503-190	211.93

† Features plastic snap-out arbor hole adapter  
†† Other arbor holes available using metal adapter. Please specify.  
\* 1/2 x 1/4 Double keyway and uses metal adapter.

DIA.	WIRE SIZE	ARBOR HOLE	TRIM LENGTH	FACE WIDTH	MAX SAFE FREE SPEED (RPM)	STD. PKG.	ITEM NO.	PRICE EACH
<b>Narrow Face</b>								
6	.014	5/8-1/2	1-1/16	5/8	6,000	1	6502-325	\$30.30
7	.014	5/8-1/2	1-9/16	3/4	6,000	1	6502-335	37.29
<b>Medium Face</b>								
6	.014	5/8-1/2	1-1/8	7/8	6,000	1	6506-645	37.67
7	.014	5/8-1/2	1-5/8	7/8	6,000	1	6506-655	43.89

## Copper Center Wire Wheels Wire Fill



DIA.	WIRE SIZE	ARBOR HOLE	TRIM LENGTH	FACE WIDTH	MAX SAFE FREE SPEED (RPM)	STD. PKG.	ITEM NO.	PRICE EACH
2	.006	1/2	1/2	3/8	20,000	10	6515-433	\$10.34
2	.014	1/2-3/8	1/2	3/8	20,000	10	6515-473	7.63
3	.006	5/8	15/16	1/2	20,000	10	6515-637	14.99
3	.014	1/2	1	1/2	20,000	10	6515-553	10.41
3	.014	1/2-3/8	1	1/2	20,000	10	6515-573	9.13

## Dualife Knot Type Wire Wheel Brushes



### Standard Twist

DIA.	WIRE SIZE	ARBOR HOLE	TRIM LENGTH	FACE WIDTH	MAX SAFE FREE SPEED (RPM)	STD. PKG.	ITEM NO.	PRICE EACH
4	.014	1/2-3/8†	7/8	1/2	20,000	10	6508-044	\$28.45
4	.020	1/2-3/8†	7/8	1/2	20,000	10	6508-064	28.09
6	.016	5/8-1/2†	1-3/8	1/2	9,000	10	6508-095	43.56
8	.016	5/8-1/2†	1-5/8	5/8	6,000	2	6508-145	65.54
8	.023	5/8-1/2†	1-5/8	5/8	6,000	2	6508-155	63.67
10	.016	1-1/4*	1-3/4	3/4	4,500	2	6508-189	92.94
12	.014	1-1/4*	2-3/4	3/4	3,600	1	6508-209	120.59
12	.020	1-1/4*	2-1/4	5/8	5,000	2	6509-719	154.48
15	.016	1-1/4*	4-1/4	7/8	3,600	2	6508-249	155.41

† Features plastic snap-out arbor hole adapter  
\* 5/16 x 5/32 Double Keyway  
Other diameters, arbor hole, or wire sizes available on request.

## Metal Adapters For Wire Wheel Brushes (Used in pairs)

ADAPTER ARBOR SIZE	STD. PKG.	ORDER SIZE	PRICE EACH
1/2	1 Pr.	6503-809	\$6.69
5/8	1 Pr.	6503-810	4.46
3/4	1 Pr.	6503-811	4.46
7/8	1 Pr.	6503-824	6.69
1	1 Pr.	6503-812	4.46
1 1/4	1 Pr.	6503-813	8.91
1-1/2	1 Pr.	6503-814	8.08



## Standard Twist Stainless Steel

DIA.	WIRE SIZE	ARBOR HOLE	TRIM LENGTH	FACE WIDTH	MAX SAFE FREE SPEED (RPM)	STD. PKG.	ITEM NO.	PRICE EACH
4	.020	1/2-3/8	7/8	1/2	20,000	10	6508-314	\$58.06
6	.016	5/8-1/2	1-3/8	1/2	9,000	2	6508-345	106.05
8	.016	5/8-1/2	1-5/8	5/8	6,000	2	6508-395	157.38

## Standard Twist-Wide Face (Double Sections)

DIA.	WIRE SIZE	ARBOR HOLE	TRIM LENGTH	FACE WIDTH	MAX SAFE FREE SPEED (RPM)	STD. PKG.	ITEM NO.	PRICE EACH
6	.016	2	1-3/8	7/8	9,000	5	6509-180	\$98.77
8	.016	2	1-5/8	1	6,000	1	6509-430	143.71
10	.016	2	1-3/4	1-1/4	4,500	1	6509-480	191.82
12	.014	2	2-3/4	1-1/4	3,600	1	6509-530	246.67

Other arbor holes available using metal adapter

**Cup Brushes**



**Knot Type - Single Row**



**Knot Type - Double Row**



**Crimped Wire**

DIA.	WIRE SIZE	ARBOR HOLE	TRIM LENGTH	MAX SAFE FREE SPEED (RPM)	STD. PKG.	ITEM NO.	PRICE EACH
<b>Knot Type – Single Row</b>							
4	.014	5/8-11	1-1/4	9,000	1	6512-306	\$45.45
4	.023	5/8-11	1-1/4	9,000	1	6512-316	41.23
4	.035	5/8-11	1-1/4	9,000	1	6512-326	41.36
6	.014	5/8-11	1-1/2	6,600	1	6512-356	88.42
6	.023	5/8-11	1-1/2	6,600	1	6512-376	82.90
6	.035	5/8-11	1-1/2	6,600	1	6512-396	81.43
<b>Knot Type – Double Row – Heavy Duty</b>							
6	.023	5/8-11	1-3/8	6,600	1	6512-556	115.49
<b>Crimped Wire Medium &amp; Light Duty Applications</b>							
4	.014	5/8-11	1-3/8	9,000	1	6514-026	37.27
4	.020	5/8-11	1-3/8	9,000	1	6514-036	34.98
6	.014	5/8-11	1-1/4	6,600	1	6514-066	63.47
6	.020	5/8-11	1-1/4	6,600	1	6514-076	57.09
<b>Knot Type – Single Row – Heavy Duty – Stainless Steel</b>							
4	.014	5/8-11	1-1/4	9,000	1	6512-406	101.61
4	.023	5/8-11	1-1/4	9,000	1	6512-416	97.36
4	.014	5/8-11	1-3/8	6,600	1	6512-456	197.41
6	.023	5/8-11	1-3/8	6,600	1	6512-476	171.06

**Mighty-Mite Brushes for Small Angle Grinders**

**Knot Type Wire Wheel- Stringer Bead Twist**

DIA.	WIRE SIZE	ARBOR HOLE	TRIM LENGTH	FACE WIDTH	MAX SAFE FREE SPEED (RPM)	STD. PKG.	ITEM NO.	PRICE EACH
4	.020	5/8-11	7/8	3/16	20,000	5	6513-131	\$21.03
4	.020	M 10 x 1.25	7/8	3/16	20,000	5	6513-125	23.13
4	Stainless .020	M 10 x 1.25	7/8	3/16	20,000	5	6513-132	42.04
4	Stainless .020	5/8-11	7/8	3/16	20,000	5	6513-138	39.27

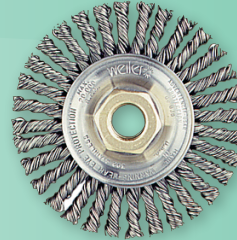

**Knot Type - Wire Wheel Cable Twist**



**Crimped Wire Cup Brush**



DIA.	WIRE SIZE	ARBOR HOLE	TRIM LENGTH	FACE WIDTH	MAX SAFE FREE SPEED (RPM)	STD. PKG.	ITEM NO.	PRICE EACH
4	.020	5/8-11	7/8	1/4	20,000	5	6513-266	\$30.79

DIA.	WIRE SIZE	ARBOR HOLE	TRIM LENGTH	MAX SAFE FREE SPEED (RPM)	STD. PKG.	ITEM NO.	PRICE EACH
3	.014	M10 x 1.25	7/8	14,000	1	6513-240	\$25.66
3	.014	5/8-11	7/8	14,000	1	6513-245	25.50

**Knot Type - Cup Brush Single Row**



DIA.	WIRE SIZE	ARBOR HOLE	TRIM LENGTH	MAX SAFE FREE SPEED (RPM)	STD. PKG.	ITEM NO.	PRICE EACH
2-3/4	.020	M10 x 1.25	7/8	14,000	1	6513-281	\$27.36
2-3/4	.020	1/2-13	7/8	14,000	1	6513-285	27.36
2-3/4	.020	5/8-11	7/8	14,000	1	6513-286	27.36

# Nylox Filament Brushes

## Nylox Wheels Crimped Filament

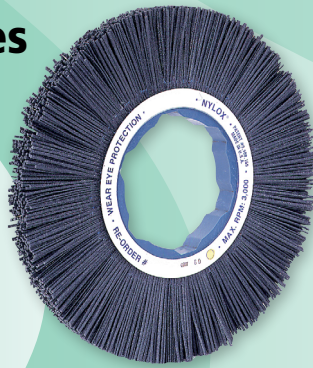

## Crimped Filament Disc Silicon Carbide – Composite Hub

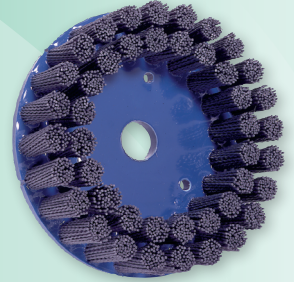

DIA.	ARBOR HOLE	FILAMENT DIAM. AND GRIT SIZE	TRIM LENGTH	FACE WIDTH	THICKNESS THROUGH ARBOR	MAX SAFE FREE SPEED (RPM)	STD. PKG.	ITEM NO.	PRICE EACH
6	2	.002/320	1-1/4	1	1-1/16	5,000	2	6583-010	\$84.46
6	2	.035/180	1-1/4	1	1-1/16	5,000	2	6583-030	84.46
6	2	.040/120	1-1/4	1	1-1/16	5,000	2	6583-040	84.46
6	2	.040/80	1-1/4	1	1-1/16	5,000	2	6583-050*	84.46
8	2	.002/320	2-1/4	1	3/4	5,000	2	6583-110	116.91
8	2	.035/180	2-1/4	1	3/4	5,000	2	6583-130	116.91
8	2	.040/120	2-1/4	1	3/4	5,000	2	6583-140*	116.91
8	2	.040/80	2-1/4	1	3/4	5,000	2	6583-150	116.91
10	2	.002/320	3	1	1-1/16	4,500	2	6583-310	156.33
10	2	.035/180	3	1	1-1/16	4,500	2	6583-330	156.33
10	2	.040/120	3	1	1-1/16	4,500	2	6583-340	156.33
10	2	.040/80	3	1	1-1/16	4,500	2	6583-350	156.33

DIAMETER INCHES	FILAMENT DIA./GRIT	ARBOR HOLE	TRIM LENGTH	MAX. RPM	ITEM NO.	PRICE EACH
4"	.022/320	7/8"	1-1/2"	2,500	6585-812	\$144.25
4"	.035/180	7/8"	1-1/2"	2,500	6585-814	144.25
4"	.040/120	7/8"	1-1/2"	2,500	6585-816	144.25
4"	.040/80	7/8"	1-1/2"	2,500	6585-818*	144.25
6"	.035/180	7/8"	1-1/2"	2,000	6585-850	215.68
6"	.040/120	7/8"	1-1/2"	2,000	6585-852	215.68
6"	.040/80	7/8"	1-1/2"	2,000	6585-854	215.68
8"	.035/180	7/8"	1-1/2"	2,000	6585-908	337.97
8"	.040/120	7/8"	1-1/2"	2,000	6585-912	337.97
8"	.040/80	7/8"	1-1/2"	2,000	6585-914	337.97

\*Minimum order quantity: (48)

Other arbor holes available using metal adapter. Please specify.

\*Minimum order quantities: 6" .040/80 (38); 8" .040/120 (50)



## Nylox Cup Brushes

DIA.	ARBOR HOLE	FILAMENT DIAM. AND GRIT SIZE	TRIM LENGTH	THICKNESS THROUGH ARBOR	MAX SAFE FREE SPEED (RPM)	STD. PKG.	ITEM NO.	PRICE EACH
2-3/4	1/4 Stem	.022/320	1-1/4	1-1/16	6,000	1	6514-401	\$46.72
2-3/4	1/4 Stem	.035/180	1-1/4	1-1/16	6,000	1	6514-403	46.45
2-3/4	1/4 Stem	.040/120	1-1/4	1-1/16	6,000	1	6514-404	46.45
3-1/2	5/8-11	.035/180	1-1/2	3/4	12,000	1	6514-413	64.65
3-1/2	5/8-11	.040/120	1-1/2	3/4	8,000	1	6514-414	64.65
5	5/8-11	.040/120	1-1/4	3/4	8,000	1	6514-576	105.50
6	5/8-11	.040/120	1-1/4	1-1/16	6,500	1	6514-516	113.87
6	5/8-11	.040/80	1-1/4	1-1/16	6,000	1	6514-506	113.87

## Rectangular Filament Disc (.045 x .090) Silicon Carbide– Composite Hub

DIAMETER INCHES	ARBOR HOLE	GRIT SIZE	TRIM LENGTH	MAX. RPM	ITEM NO.	PRICE EACH
4"	7/8"	180	1-1/2"	2,500	6585-822	\$158.66
4"	7/8"	120	1-1/2"	2,500	6585-824*	158.66
4"	7/8"	80	1-1/2"	2,500	6585-826	158.66
6"	7/8"	120	1-1/2"	2,000	6585-860*	218.36
6"	7/8"	80	1-1/2"	2,000	6585-862	218.36
8"	7/8"	120	1-1/2"	2,000	6585-920	347.74
8"	7/8"	80	1-1/2"	2,000	6585-922*	347.74

\*Min. order quantities: 4" 120G (48); 6" 120G (30); 8" 80G (30)

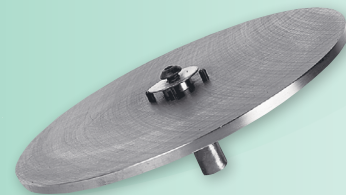

## Nylox Tube Brushes

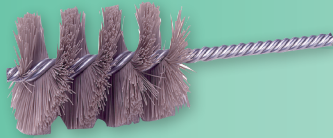

DIA.	FILAMENT DIA. AND GRIT SIZE	BRUSH LENGTH	STEM DIA.	OVERALL LENGTH	STD. PKG.	ITEM NO.	PRICE EACH
1/4	.002/320	1-1/2	1/8	4	10	6521-126	\$11.59
3/8	.035/180	1-1/2	1/8	4	10	6521-128	11.75
1/2	.040/120	2	5/32	5	10	6521-130*	10.26
5/8	.002/320	2	7/32	5	10	6521-132	10.80
3/4	.035/180	2-1/2	7/32	5-1/2	10	6521-134	10.93
7/8	.040/120	2-1/2	1/4	5-1/2	10	6521-136	11.63
1	.040/120	2-1/2	1/4	5-1/2	10	6521-138	11.06
1-1/8	.002/320	2-1/2	1/4	5-1/2	10	6521-302	7.60
1-1/4	.035/180	2-1/2	1/4	5-1/2	10	6521-306	11.82
1-1/2	.040/120	2-1/2	1/4	5-1/2	10	6521-309	12.31

\*Minimum order quantity: (40)

## Nylon Disc Brush Drive Arbors

Mounts Weiler disc brushes to any type of milling machine or CNC machine

DESCRIPTION	ITEM NO.	PRICE EACH
For 4" diameter disc brushes with 1-1/4" diameter bolt circle	6507-700	\$279.66
For 6" diameter disc brushes with 3" diameter bolt circle	6507-701	341.85
For 8" diameter disc brushes with 3" diameter bolt circle	6507-702	370.74
Standard 3/4" diameter shaft, 2" long. Standard 7/8" diameter shouldered spindle.		

**Power and Hand Tube Brushes**



**Single Stem, Single Spiral "STS" Type - Eye Handle**

DIA.	WIRE SIZE	BRUSH LENGTH	STEM DIAM.	OVERALL LENGTH	STD. PKG.	ITEM NO.	PRICE EACH
3/16	.003	1-1/2	3/32	7	10	6521-090	\$6.33
3/16	.005	1-1/2	3/32	7	10	6521-091	6.33
1/4	.003	1-1/2	3/32	7	10	6521-092	7.11
1/4	.005	1-1/2	3/32	7	10	6521-093	6.15
3/8	.004	2	1/8	8	10	6521-094	6.40
3/8	.006	2	1/8	8	10	6521-095	5.04
1/2	.004	2	1/8	8	10	6521-096	6.40
1/2	.006	2	1/8	8	10	6521-097	5.04

**Single Stem, Round "SM" Type - Stainless Steel Stem**



Steel Wire							
1/4	.004	1	1/8	3-1/2	10	6521-072	\$5.51
3/8	.004	1	1/8	3-1/2	10	6521-073	5.60
3/8	.008	1	3/16	3-1/2	10	6521-264	4.81
1/2	.005	1	3/16	3-1/2	10	6521-074	5.12
5/8	.005	1	3/16	3-1/2	10	6521-075	5.31
5/8	.008	1	3/16	3-1/2	10	6521-265	6.08
3/4	.006	1	7/32	3-1/2	10	6521-076	6.08
3/4	.008	1	7/32	3-1/2	10	6521-266*	5.98
7/8	.006	1	7/32	3-1/2	10	6521-077	6.29
1	.005	1	1/4	3-1/2	10	6521-078	6.88
1-1/8	.008	1	1/4	3-1/2	10	6521-079	6.91
1-1/4	.008	1	1/4	3-1/2	10	6521-080	6.88
Stainless Steel Wire							
1/4	.004	1	1/8	3-1/2	10	6521-081	6.66
3/8	.008	1	1/8	3-1/2	10	6521-240	5.55
1/2	.005	1	3/16	3-1/2	10	6521-083	6.80
5/8	.005	1	3/16	3-1/2	10	6521-084	6.80
3/4	.006	1	7/32	3-1/2	10	6521-085	6.80
7/8	.006	1	7/32	3-1/2	10	6521-086	6.85
1	.008	1	1/4	3-1/2	10	6521-087	8.24

\*Minimum order quantity: (40)

**Single Stem, Double Spiral "DS" Type**



Single Stem, Double Spiral "DS" Type							
1/2	.006	2	5/32	5	10	6521-107	\$13.20
5/8	.008	2	7/32	5	10	6521-109	13.42
3/4	.0104	2-1/2	1/4	5-1/2	10	6521-111	13.64
7/8	.0104	2-1/2	1/4	5-1/2	10	6521-113	14.15
1	.0104	2-1/2	1/4	5-1/2	10	6521-115	13.91
1-1/4	.0104	2-1/2	1/4	5-1/2	10	6521-167	14.52

**End Brushes**



**Solid End**



**Knot Type**



**Crimped Wire Cup**

							STAINLESS	
DIA.	WIRE SIZE	TRIM LENGTH	MAX SAFE FREE SPEED (RPM)	STD. PKG.	ITEM NO.	PRICE EACH	ITEM NO.	PRICE EACH
Solid End								
1/2	.006	7/8	25,000	10	6510-001	\$10.46	6510-013	\$13.48
1/2	.0104	7/8	25,000	10	6510-002	9.72	6510-014	12.43
1/2	.014	7/8	25,000	10	6510-003	9.22	6510-015	11.87
1/2	.020	7/8	25,000	10	6510-004	8.93	6510-016	11.76
3/4	.006	7/8	22,000	10	6510-005	16.13	6510-017	19.52
3/4	.0104	7/8	22,000	10	6510-006	12.25	6510-018	17.55
3/4	.014	7/8	22,000	10	6510-007	12.12	6510-019	17.39
3/4	.020	7/8	22,000	10	6510-008	11.68	6510-020	16.88
1	.006	7/8	22,000	10	6510-009	19.26	6510-021	27.13
1	.0104	7/8	22,000	10	6510-010	14.29	6510-022	25.00
1	.014	7/8	22,000	10	6510-011	14.29	6510-023	24.85
1	.020	7/8	22,000	10	6510-012	12.56	6510-024	23.68
Knot Type								
3/4	.020	7/8	20,000	10	6510-026	18.63	6510-030	32.64
1-1/8	.014	7/8	20,000	10	6510-027	20.55	6510-031	42.21
1-1/8	.020	7/8	20,000	10	6510-028	20.23	6510-032	37.82
Crimped Wire Cup Brushes								
1-3/4"	.006	3/4"	13,000	10	6514-300	15.90	-	-
1-3/4"	.0118	3/4"	13,000	10	6514-301	14.03	6514-304	30.92
2-3/4"	.0118	7/8"	6,000	1	6514-302	21.49	-	-

**Conflex Narrow Face Crimped Wire Wheel**



							STAINLESS	
DIA.	WIRE SIZE	TRIM LENGTH	MAX SAFE FREE SPEED (RPM)	STD. PKG.	ITEM NO.	PRICE EACH	ITEM NO.	PRICE EACH
2	.006	1/2	20,000	10	6517-609	\$19.66	-	-
2	.0118	1/2	20,000	10	6517-610	17.54	-	-
2 1/2	.006	3/4	20,000	10	6517-612	22.52	6517-611	\$28.86
2 1/2	.014	3/4	20,000	10	6517-614	14.96	-	-
3	.008	1	20,000	10	6517-615	22.87	-	-
3	.0118	1	20,000	10	6517-616	17.37	-	-
3	.014	1	20,000	10	6517-617	16.21	6517-618	39.96

## Hand Wire Scratch Brushes

### Curved Handle



FILL MATERIAL	NUMBER OF ROWS	BLOCK SIZE	BRUSH PART	TRIM LENGTH	STD. PKG.	ITEM NO.	PRICE EACH
.012 STEEL	3 x 19	13 x 1/2 x 1	6	1	12	6525-150	\$2.26
.012 SS	3 x 19	13 x 1/2 x 1	6	1	12	6525-154	3.59
.012 STEEL†	3 x 19	14 x 7/8	5-1/2	1-3/16	12	6544-055	5.58
.012 SS	4 x 18	14 x 1-1/8	6	1	12	6525-202	5.08
.012 STEEL†	4 x 19	14 x 1-1/8	6	1-3/16	12	6544-058	8.06

† With Scraper

### Block Type



FILL MATERIAL	NUMBER OF ROWS	BLOCK SIZE	TRIM LENGTH	STD. PKG.	ITEM NO.	PRICE EACH
.012 STEEL	6 x 19	7-1/4 x 2-1/4	1-5/8	12	6544-067	\$7.43

### Scraper Type



FILL MATERIAL	NUMBER OF ROWS	BLOCK SIZE	BRUSH PART	TRIM LENGTH	STD. PKG.	ITEM NO.	PRICE EACH
.012 STEEL	4 x 11	11 x 1-1/2	5	1-5/8	12	6525-211	\$3.99

### Shoe Handle



FILL MATERIAL	NUMBER OF ROWS	BLOCK SIZE	BRUSH PART	TRIM LENGTH	STD. PKG.	ITEM NO.	PRICE EACH
.012 STEEL	4 x 16	10 x 1	5	1	12	6525-100	\$2.46
.012 SS	4 x 16	10 x 1	5	1	12	6525-104	4.20
.012 STEEL†	4 x 16	10 x 1-1/8	5	1-3/16	12	6544-065	7.09

† With Scraper

### Small



HANDLE	FILL MATERIAL	NUMBER OF ROWS	BLOCK SIZE	BRUSH PART	TRIM LENGTH	STD. PKG.	ITEM NO.	PRICE EACH
Plastic	.006 SS	3 x 7	7-1/2 x 1/2	1-3/8	1/2	36	6544-075	\$2.94
Wood	.006 SS	3 x 7	7-1/2 x 1/2	1-3/8	1/2	36	6544-167	2.58
Wood	.006 Brass	3 x 7	7-1/2 x 1/2	1-3/8	1/2	36	6544-189	3.53

### Chip and Oil Brushes

Natural White Bristle  
Wood Handle



WIDTH	THICKNESS	BRISTLE LENGTH	STD. PKG.	ITEM NO.	PRICE EACH
1/2	5/16	1-3/4	30	6540-065	\$0.35
1	5/16	1-3/4	30	6540-066	0.37
1-1/2	5/16	1-3/4	30	6540-067	0.48
2	5/16	1-3/4	20	6540-068	0.57
2-1/2	3/8	1-3/4	20	6540-069	0.76
3	3/8	1-3/4	10	6540-070	1.00
4	5/8	2	10	6540-071	1.96

### Counter Dusters



FILL MATERIAL	BRUSH LENGTH	TRIM LENGTH	STD. PKG.	ITEM NO.	PRICE EACH
Black Tampico	8	2-1/2	12	6525-251	\$8.29
Black Synthetic	8	2-1/2	12	6525-252	6.60
Black Horsehair	8	2-1/8	12	6544-003	13.49
Grey Tampico	8	2-1/2	12	6544-004	7.96



### Parts Cleaning Brush



FILL MATERIAL	DIA.	BRISTLE LENGTH	STD. PKG.	ITEM NO.	PRICE EACH
Nylon	1	2-1/2	12	6525-221	\$3.48
Tampico	1	2-3/4	12	6525-222	3.62

### Tin Handle Acid Brushes

WIDTH	TRIM LENGTH	OVERALL LENGTH	STD. PKG.	ITEM NO.	PRICE EACH
3/8	3/4	5-3/4	144	6544-089	\$0.25
1/2	3/4	5-3/4	144	6544-090	0.32

### Floor Brushes



Fine Sweeping



Medium Sweeping



Coarse Sweeping

DESCRIPTION	TRIM LENGTH	STD. PKG.	ITEM NO.	PRICE EACH
<b>Fine Sweeping</b>				
18 Block Black Tampico	2-7/8	1	6525-231	\$ 14.95
24 Block Black Synthetic	2-7/8	1	6525-232	21.34
<b>Medium Sweeping</b>				
18 Block Synthetic	3	1	6525-234	13.70
24 Block Synthetic	3	1	6525-235	19.10

DESCRIPTION	TRIM LENGTH	STD. PKG.	ITEM NO.	PRICE EACH
<b>Coarse Sweeping</b>				
18 Block Synthetic	3-1/4	1	6525-238	\$ 13.54
24 Block Synthetic	3-1/4	1	6525-239	19.89
<b>Garage Sweeping</b>				
18 Block Palmyra	4	1	6525-241	12.19
24 Block Palmyra	4	1	6525-242	17.08

### Handles

Threaded End -  
60" Overall Length  
15/16" Diameter  
Order No. 6544-018

Price Each .....\$6.71

# Surface Grinding Wheels



2

## Vitrified Bonded for Rich Stock Removal and Excellent Rigidity for Precision Grinding

### WA – White Aluminum Oxide

Friable grain for light grinding of all steels, particularly tool & die steels.

### AZ – Premium Blue Aluminum Oxide

Suitable for HSS grinding on materials 55RC and above. Exceptionally cool, fast cutting.

### CG – Green Silicon Carbide

General purpose grinding on tungsten carbide and non-ferrous metals.

### AS3 – Synthetic Ceramic Blend

Features a blend of synthetic ceramic grain with PA and WA grains for optimum fracturing. Provides a continuous, sharp cutting action.

### 32A – Premium Aluminum Oxide

Outstanding firm holding wheels with free cutting grain, ideal for medium to heavy stock removal. Excellent versatility and performance on a wide range of materials.



**Buy Ctn Qty Deduct 20%**

### RA – Ruby Aluminum Oxide

For fast stock removal on tool steels below 55RC and for high chromium steels. This grain is harder than the PA and AZ.

### 6 x 1/2 x 1-1/4 – No Recess

GRIT/HARDNESS	MAX RPM	CTN QTY	WHITE ALUMINUM OXIDE (TYPE WA)		PREMIUM BLUE ALUMINUM OXIDE (TYPE AZ)		SILICON CARBIDE (TYPE CG)	
			ORDER NO.	PRICE EACH	ORDER NO.	PRICE EACH	ORDER NO.	PRICE EACH
60K	4456	10	–	–	3323-024	\$18.00	–	–

### 7 x 1/4 x 1-1/4 – No Recess

GRIT/HARDNESS	MAX RPM	CTN QTY	WHITE ALUMINUM OXIDE (TYPE WA)		PREMIUM BLUE ALUMINUM OXIDE (TYPE AZ)		SILICON CARBIDE (TYPE CG)		SYNTHETIC CERAMIC GRAIN (TYPE AS3)	
			ORDER NO.	PRICE EACH	ORDER NO.	PRICE EACH	ORDER NO.	PRICE EACH	ORDER NO.	PRICE EACH
46I	3760	10	3320-102	\$15.75	3323-102	\$15.90	–	–	–	–
60I	3760	10	3320-120	15.75	3323-120	15.90	3275-120	\$18.95	–	–
60J	3760	10	3320-122	15.75	3323-122	15.90	–	–	–	–
60K	3760	10	3320-124	15.75	3323-124	15.90	–	–	–	–
80I	3760	10	–	–	–	–	3275-130	18.95	–	–
80J	3760	10	3320-130	15.75	3323-130	15.90	–	–	–	–
80K	3760	10	3320-132	15.75	3323-132	15.90	–	–	3326-134	\$28.70
100I	3760	10	–	–	–	–	3275-140	18.95	–	–
100K	3760	10	3320-148	15.75	3323-148	15.90	–	–	–	–
120K	3760	10	3320-162	15.75	–	–	–	–	–	–
150K	3760	10	3320-186	15.75	3323-186	15.90	–	–	–	–

† Limited Quantities

### 7 x 1/2 x 1-1/4 – No Recess

GRIT/HARDNESS	MAX RPM	CTN QTY	WHITE ALUMINUM OXIDE (TYPE WA)		PREMIUM BLUE ALUMINUM OXIDE (TYPE AZ)		PREMIUM GRAY ALUMINUM OXIDE (TYPE 32A)		SILICON CARBIDE (TYPE CG)		SYNTHETIC CERAMIC GRAIN (TYPE AS3)	
			ORDER NO.	PRICE EACH	ORDER NO.	PRICE EACH	ORDER NO.	PRICE EACH	ORDER NO.	PRICE EACH	ORDER NO.	PRICE EACH
46G	3760	10	3320-300†	\$11.20	–	–	–	–	–	–	–	–
46H	3760	10	3320-302	18.75	3323-302	\$20.15	3330-302	\$23.85	–	–	3326-202	\$39.05
46I	3760	10	3320-304	18.75	3323-304	20.15	3330-304	23.85	–	–	–	–
46J	3760	10	3320-306	18.75	3323-306	20.15	3330-306	23.85	–	–	3326-204	39.05
46K	3760	10	3320-308	18.75	3323-308	20.15	3330-308	23.85	–	–	–	–
60H	3760	10	3320-320	18.75	3323-320†	11.15	–	–	–	–	–	–
60I	3760	10	3320-322	18.75	3323-322	20.15	3330-322	23.85	3275-320	\$25.85	–	–
60J	3760	10	3320-324	18.75	3323-324	20.15	–	–	–	–	–	–
60K	3760	10	3320-326	18.75	3323-326	20.15	–	–	–	–	3326-224	39.05
80H	3760	10	–	–	3323-342	20.15	–	–	–	–	–	–
80I	3760	10	–	–	–	–	–	–	3275-330	25.85	–	–
80K	3760	10	3320-346	18.75	3323-346	20.15	–	–	–	–	–	–
100I	3760	10	–	–	–	–	–	–	3275-340	25.85	–	–
100K	3760	10	3320-360	18.75	3323-360	20.15	–	–	–	–	–	–
120K	3760	10	3320-374	18.75	–	–	–	–	–	–	–	–
150K	3760	10	3320-386	18.75	3323-386	20.15	–	–	–	–	–	–

† Limited Quantities



# Surface Grinding Wheels



2

**Buy  
Ctn Qty  
Deduct  
20%**

## Ruby Red Aluminum Oxide

7 x 1/2 x 1-1/4 – No Recess

GRIT/ HARDNESS	MAX RPM	TYPE RA		
		CTN QTY	ORDER NO.	PRICE EACH
46H	3760	10	3280-102	\$25.30
46J/K	3760	10	3280-108	25.30
60J/K	3760	10	3280-120	25.30

7 x 1/2 x 1-1/4 – Porous Bond – No Recess

GRIT/ HARDNESS	MAX RPM	CTN QTY	PREMIUM BLUE ALUMINUM OXIDE (TYPE AZ)	
			ORDER NO.	PRICE EACH
46H12	3760	10	3323-402	\$22.20

7 x 3/4 x 1-1/4 – Recessed One Side 3 x 1/4"

GRIT/ HARDNESS	MAX RPM	CTN QTY	WHITE ALUMINUM OXIDE (TYPE WA)		PREMIUM BLUE ALUMINUM OXIDE (TYPE AZ)		SILICON CARBIDE (TYPE CG)		SYNTHETIC CERAMIC GRAIN (TYPE AS3)	
			ORDER NO.	PRICE EACH	ORDER NO.	PRICE EACH	ORDER NO.	PRICE EACH	ORDER NO.	PRICE EACH
46H	3760	10	3320-500	\$25.55	3323-500	\$27.80	-	-	-	-
46I	3760	10	-	-	3323-502	27.80	-	-	-	-
46J	3760	10	3320-504	25.55	3323-504	27.80	-	-	-	-
46K	3760	10	3320-506†	13.40	3323-506†	14.35	-	-	-	-
60H	3760	10	3320-518	25.55	3323-518†	11.05	-	-	-	-
60I	3760	10	3320-520†	8.65	3323-520†	9.50	3275-520	\$32.00	-	-
60J	3760	10	3320-522	25.55	3323-522	27.80	-	-	-	-
60K	3760	10	3320-524†	13.45	-	-	-	-	-	-
80I	3760	10	-	-	-	-	3275-530	33.25	-	-
100I	3760	10	-	-	-	-	3275-540†	18.55	-	-

† Limited Quantities

7 x 1 x 1-1/4 – Recessed One Side 3 x 1/2"

GRIT/ HARDNESS	MAX RPM	CTN QTY	WHITE ALUMINUM OXIDE (TYPE WA)		PREMIUM BLUE ALUMINUM OXIDE (TYPE AZ)		SILICON CARBIDE (TYPE CG)		SYNTHETIC CERAMIC GRAIN (TYPE AS3)	
			ORDER NO.	PRICE EACH	ORDER NO.	PRICE EACH	ORDER NO.	PRICE EACH	ORDER NO.	PRICE EACH
46H	3760	10	3320-700	\$29.95	3323-700	\$32.05	-	-	-	-
46I	3760	10	3320-702	29.95	3323-702	32.05	-	-	-	-
46J	3760	10	3320-704	29.95	3323-704	32.05	-	-	-	-
46K	3760	10	-	-	3323-706	32.05	-	-	-	-
60I	3760	10	3320-720	29.95	-	-	3275-720	\$39.00	-	-
60J	3760	10	3320-722	29.95	3323-722	32.05	-	-	-	-
60K	3760	10	-	-	3323-724	32.05	-	-	-	-
80I	3760	10	-	-	-	-	3275-730	39.00	-	-
100I	3760	10	-	-	-	-	3275-740	39.00	-	-

† Limited Quantities

8 x 1/4 x 1-1/4 – No Recess

GRIT/ HARDNESS	MAX RPM	CTN QTY	WHITE ALUMINUM OXIDE (TYPE WA)		PREMIUM BLUE ALUMINUM OXIDE (TYPE AZ)		SILICON CARBIDE (TYPE CG)		SYNTHETIC CERAMIC GRAIN (TYPE AS3)	
			ORDER NO.	PRICE EACH	ORDER NO.	PRICE EACH	ORDER NO.	PRICE EACH	ORDER NO.	PRICE EACH
46H	3600	10	3320-850†	\$8.80	-	-	-	-	-	-
60K	3600	10	3320-874	21.20	-	-	-	-	-	-
80I	3600	10	-	-	-	-	3275-830	\$26.55	-	-
80J	3600	10	3320-884	21.20	-	-	-	-	-	-

† Limited Quantities

# Surface Grinding Wheels



2

## 8 x 1/2 x 1-1/4 – No Recess

GRIT/ HARDNESS	MAX RPM	CTN QTY	WHITE ALUMINUM OXIDE (TYPE WA)		PREMIUM BLUE ALUMINUM OXIDE (TYPE AZ)		SILICON CARBIDE (TYPE CG)		GREY ALUMINUM OXIDE (TYPE 32A)		SYNTHETIC CERAMIC GRAIN (TYPE AS3)	
			ORDER NO.	PRICE EACH	ORDER NO.	PRICE EACH	ORDER NO.	PRICE EACH	ORDER NO.	PRICE EACH	ORDER NO.	PRICE EACH
46H	3600	10	3320-900	\$25.80	3323-900	\$26.75	-	-	-	-	-	-
46I	3600	10	3320-902	25.80	3323-902	26.75	-	-	3330-902	\$29.50	-	-
46J	3600	10	3320-904	25.80	3323-904	26.75	-	-	3330-904	29.50	-	-
46K	3600	10	3320-906	25.80	3323-906	26.75	-	-	-	-	3326-406	\$53.85
60H	3600	10	-	-	3323-918	26.75	-	-	-	-	-	-
60I	3600	10	3320-920	25.80	3323-920	26.75	3275-920	\$34.45	-	-	-	-
60J	3600	10	3320-922	25.80	3323-922	26.75	-	-	-	-	3326-424	53.85
60K	3600	10	3320-924	25.80	3323-924	26.75	-	-	-	-	-	-
80I	3600	10	-	-	-	-	3275-930	34.45	-	-	-	-
80K	3600	10	3320-936	25.80	3323-936	26.75	-	-	-	-	-	-
100I	3600	10	-	-	-	-	3275-940	34.45	-	-	-	-

## 8 x 1/2 x 1-1/4 – Porous Bond - No Recess

RUBY ALUMINUM OXIDE (TYPE RA)				
GRIT/ HARDNESS	MAX RPM	CTN QTY	ORDER NO.	PRICE EACH
46H12	3600	10	3277-133	\$39.30
60H12	3600	10	3277-138	39.30

## 8 x 3/4 x 1-1/4 – Recessed One Side 3 x 1/4"

GRIT/ HARDNESS	MAX RPM	CTN QTY	WHITE ALUMINUM OXIDE (TYPE WA)		PREMIUM BLUE ALUMINUM OXIDE (TYPE AZ)		SILICON CARBIDE (TYPE CG)		SYNTHETIC CERAMIC GRAIN (TYPE AS3)	
			ORDER NO.	PRICE EACH	ORDER NO.	PRICE EACH	ORDER NO.	PRICE EACH	ORDER NO.	PRICE EACH
46H	3600	10	3321-000	\$34.75	3324-000	\$34.75	-	-	-	-
46J	3600	10	3321-004	34.75	3324-004	34.75	-	-	-	-
46K	3600	10	3321-006†	10.80	-	-	-	-	-	-
60I	3600	10	3321-020	34.75	-	-	3276-020	\$41.80	-	-
60J	3600	10	3321-022	34.75	3324-022	34.75	-	-	-	-
60K	3600	10	3321-024	34.75	-	-	-	-	-	-

† Limited Quantities

## 8 x 1 x 1-1/4 – Recessed One Side 3 x 1/2"

GRIT/ HARDNESS	MAX RPM	CTN QTY	WHITE ALUMINUM OXIDE (TYPE WA)		PREMIUM BLUE ALUMINUM OXIDE (TYPE AZ)		SILICON CARBIDE (TYPE CG)		SYNTHETIC CERAMIC GRAIN (TYPE AS3)	
			ORDER NO.	PRICE EACH	ORDER NO.	PRICE EACH	ORDER NO.	PRICE EACH	ORDER NO.	PRICE EACH
46H	3600	10	-	-	3324-100	\$38.80	-	-	-	-
46J	3600	10	3321-104	\$40.20	3324-104	38.80	-	-	-	-
46K	3600	10	3321-106	40.20	-	-	-	-	-	-
60I	3600	10	3321-120	40.20	-	-	3276-120	\$47.45	-	-
60J	3600	10	3321-122	40.20	3324-122	38.80	-	-	-	-
60K	3600	10	3321-124	40.20	-	-	-	-	-	-
100I	3600	10	-	-	-	-	3276-140	47.45	-	-

† Limited Quantities

## 10 x 1/2 x 3 – No Recess

GRIT/ HARDNESS	MAX RPM	CTN QTY	WHITE ALUMINUM OXIDE (TYPE WA)		PREMIUM BLUE ALUMINUM OXIDE (TYPE AZ)		SILICON CARBIDE (TYPE CG)		SYNTHETIC CERAMIC GRAIN (TYPE AS3)	
			ORDER NO.	PRICE EACH	ORDER NO.	PRICE EACH	ORDER NO.	PRICE EACH	ORDER NO.	PRICE EACH
46J	2674	5	-	-	3324-204†	\$19.10	-	-	-	-
60K	2674	5	3321-224†	\$17.35	-	-	-	-	-	-

† Limited Quantities

# Surface Grinding Wheels



Buy  
Ctn Qty  
Deduct  
20%

2

## 10 x 3/4 x 3 – No Recess

GRIT/ HARDNESS	MAX RPM	CTN QTY	WHITE ALUMINUM OXIDE (TYPE WA)		PREMIUM BLUE ALUMINUM OXIDE (TYPE AZ)		SILICON CARBIDE (TYPE CG)		SYNTHETIC CERAMIC GRAIN (TYPE ASS)	
			ORDER NO.	PRICE EACH	ORDER NO.	PRICE EACH	ORDER NO.	PRICE EACH	ORDER NO.	PRICE EACH
46I	2674	5	–	–	3324-302†	\$29.40	–	–	–	–
60H	2674	5	–	–	3324-318	52.00	–	–	–	–
60K	2674	5	3321-324†	\$15.10	–	–	–	–	–	–

† Limited Quantities

## 10 x 1 x 3 – No Recess

GRIT/ HARDNESS	MAX RPM	CTN QTY	WHITE ALUMINUM OXIDE (TYPE WA)		PREMIUM BLUE ALUMINUM OXIDE (TYPE AZ)		SILICON CARBIDE (TYPE CG)		SYNTHETIC CERAMIC GRAIN (TYPE ASS)	
			ORDER NO.	PRICE EACH	ORDER NO.	PRICE EACH	ORDER NO.	PRICE EACH	ORDER NO.	PRICE EACH
46H	2674	5	3321-500†	\$37.95	–	–	–	–	–	–
46I	2674	5	3321-502†	17.35	3324-502	\$61.80	–	–	–	–
46J	2674	5	3321-504	60.65	3324-504	61.80	–	–	–	–
46K	2674	5	3321-506†	25.25	3324-506	61.80	–	–	3326-706	\$135.45
60H	2674	5	–	–	3324-518†	28.60	–	–	–	–
60I	2674	5	3321-520†	25.25	–	–	–	–	–	–
60J	2674	5	3321-522	60.65	3324-522	61.80	–	–	–	–
60K	2674	5	–	–	3324-524	61.80	–	–	–	–

† Limited Quantities

## 12 x 3/4 x 3 – No Recess

GRIT/ HARDNESS	MAX RPM	CTN QTY	WHITE ALUMINUM OXIDE (TYPE WA)		PREMIUM BLUE ALUMINUM OXIDE (TYPE AZ)		SILICON CARBIDE (TYPE CG)		SYNTHETIC CERAMIC GRAIN (TYPE ASS)	
			ORDER NO.	PRICE EACH	ORDER NO.	PRICE EACH	ORDER NO.	PRICE EACH	ORDER NO.	PRICE EACH
46K	2228	4	3321-606†	\$27.20	–	–	–	–	–	–

† Limited Quantities

## 12 x 1 x 3 – No Recess

GRIT/ HARDNESS	MAX RPM	CTN QTY	WHITE ALUMINUM OXIDE (TYPE WA)		PREMIUM BLUE ALUMINUM OXIDE (TYPE AZ)		SILICON CARBIDE (TYPE CG)		SYNTHETIC CERAMIC GRAIN (TYPE ASS)	
			ORDER NO.	PRICE EACH	ORDER NO.	PRICE EACH	ORDER NO.	PRICE EACH	ORDER NO.	PRICE EACH
46H	2228	2	3321-700	\$87.85	3324-700	\$85.25	–	–	3326-902	\$188.95
46J	2228	2	3321-704	87.85	3324-704	85.25	–	–	3326-904	188.95
46K	2228	2	3321-706†	38.90	3324-706	85.25	–	–	–	–
60I	2228	2	–	–	–	–	–	–	3326-922	188.95
60K	2228	2	–	–	3324-724	85.25	–	–	–	–

† Limited Quantities

# Surface Grinding Wheels



**CGW**  
CAMEL GRINDING WHEELS

2

**Buy  
Ctn Qty  
Deduct  
20%**

\*Except 12 x 2 x 5

## 12 x 1 x 5 – No Recess

GRIT/ HARDNESS	MAX RPM	CTN QTY	WHITE ALUMINUM OXIDE (TYPE WA)		PREMIUM BLUE ALUMINUM OXIDE (TYPE AZ)		SILICON CARBIDE (TYPE CG)		SYNTHETIC CERAMIC GRAIN (TYPE AS3)	
			ORDER NO.	PRICE EACH	ORDER NO.	PRICE EACH	ORDER NO.	PRICE EACH	ORDER NO.	PRICE EACH
46H	2228	2	3321-800	\$87.85	3324-800	\$85.25	-	-	3326-932	\$188.95
46I	2228	2	3321-802†	32.85	-	-	-	-	-	-
46J	2228	2	3321-804	87.85	3324-804	85.25	-	-	-	-
46K	2228	2	3321-806†	31.80	3324-806	85.25	-	-	-	-
60J	2228	2	3321-822	87.85	3324-822	85.25	-	-	-	-
60K	2228	2	-	-	3324-824	85.25	-	-	-	-

† Limited Quantities

## 12 x 1-1/2 x 3 – Recessed One Side 7-1/2 x 1/2"

GRIT/ HARDNESS	MAX RPM	CTN QTY	WHITE ALUMINUM OXIDE (TYPE WA)		PREMIUM BLUE ALUMINUM OXIDE (TYPE AZ)		SILICON CARBIDE (TYPE CG)		SYNTHETIC CERAMIC GRAIN (TYPE AS3)	
			ORDER NO.	PRICE EACH	ORDER NO.	PRICE EACH	ORDER NO.	PRICE EACH	ORDER NO.	PRICE EACH
46H	2228	2	3321-900	\$125.05	-	-	-	-	-	-
46I	2228	2	3321-902	125.05	-	-	-	-	-	-
46J	2228	2	3321-904	125.05	-	-	-	-	-	-
60I	2228	2	3321-920	125.05	-	-	-	-	-	-

## 12 x 1-1/2 x 5 – Recessed One Side 7-1/2 x 1/2"

GRIT/ HARDNESS	MAX RPM	CTN QTY	WHITE ALUMINUM OXIDE (TYPE WA)		PREMIUM BLUE ALUMINUM OXIDE (TYPE AZ)		SILICON CARBIDE (TYPE CG)		SYNTHETIC CERAMIC GRAIN (TYPE AS3)	
			ORDER NO.	PRICE EACH	ORDER NO.	PRICE EACH	ORDER NO.	PRICE EACH	ORDER NO.	PRICE EACH
46H	2228	2	3322-000	\$125.05	3325-000	\$124.95	-	-	-	-
46I	2228	2	3322-002	125.05	-	-	-	-	-	-
46J	2228	2	3322-004	125.05	3325-004	124.95	-	-	-	-
46K	2228	2	-	-	3325-006	124.95	-	-	-	-
60I	2228	2	3322-020	125.05	-	-	-	-	-	-
60J	2228	2	3322-022	125.05	3325-022	124.95	-	-	-	-

## 12 x 2 x 5 – Recessed Two Sides 7-1/2 x 1/2"

GRIT/ HARDNESS	MAX RPM	CTN QTY	WHITE ALUMINUM OXIDE (TYPE WA)		PREMIUM BLUE ALUMINUM OXIDE (TYPE AZ)		SILICON CARBIDE (TYPE CG)		SYNTHETIC CERAMIC GRAIN (TYPE AS3)	
			ORDER NO.	PRICE EACH	ORDER NO.	PRICE EACH	ORDER NO.	PRICE EACH	ORDER NO.	PRICE EACH
46H	2228	1	-	-	3325-100	\$133.05	-	-	-	-
46I	2228	1	3322-102	\$133.30	3325-102	133.05	-	-	-	-
46J	2228	1	3322-104	133.30	-	-	-	-	-	-
60H	2228	1	3322-118	133.30	3325-118	133.05	-	-	-	-

\* Carton Qty. deduction not applicable

# Surface Grinding Wheels



2

**Buy  
Ctn Qty  
Deduct  
20%**

\*Except 12 x 2 x 5

## 14 x 1 x 5 – No Recess

GRIT/ HARDNESS	MAX RPM	CTN QTY	WHITE ALUMINUM OXIDE (TYPE WA)		PREMIUM BLUE ALUMINUM OXIDE (TYPE AZ)		GREY ALUMINUM OXIDE (TYPE 32A)		SYNTHETIC CERAMIC GRAIN (TYPE AS3)	
			ORDER NO.	PRICE EACH	ORDER NO.	PRICE EACH	ORDER NO.	PRICE EACH	ORDER NO.	PRICE EACH
46H	1910	2	-	-	3325-200	\$138.40	3332-200	\$150.80	-	-
46I	1910	2	3322-202	\$123.15	3325-202	138.40	3332-202	150.80	-	-
46J	1910	2	-	-	3325-204	138.40	-	-	3326-954	\$233.95
60I	1910	2	3322-220	123.15	3325-220	138.40	-	-	-	-
60K	1910	2	3322-224	123.15	3325-224	138.40	-	-	-	-

## 14 x 1-1/2 x 5 – No Recess

GRIT/ HARDNESS	MAX RPM	CTN QTY	WHITE ALUMINUM OXIDE (TYPE WA)		PREMIUM BLUE ALUMINUM OXIDE (TYPE AZ)		GRAY ALUMINUM OXIDE (TYPE 32A)	
			ORDER NO.	PRICE EACH	ORDER NO.	PRICE EACH	ORDER NO.	PRICE EACH
46H	1910	2	3322-250	\$165.15	3325-250	\$185.60	3332-250	\$198.50
46I	1910	2	3322-252	165.15	-	-	3332-254	198.50
46J	1910	2	3322-254	165.15	3325-254	185.60	-	-
46K	1910	2	-	-	3325-256	185.60	-	-
60H	1910	2	-	-	3325-268	185.60	-	-
60J	1910	2	-	-	3325-272	185.60	-	-

## 14 x 1-1/2 x 5 – Recessed One Side 8 x 1/2"

GRIT/ HARDNESS	MAX RPM	CTN QTY	WHITE ALUMINUM OXIDE (TYPE WA)		PREMIUM BLUE ALUMINUM OXIDE (TYPE AZ)		SYNTHETIC CERAMIC GRAIN (TYPE AS3)	
			ORDER NO.	PRICE EACH	ORDER NO.	PRICE EACH	ORDER NO.	PRICE EACH
46H	1910	2	3322-300	\$165.15	3325-300	\$185.60	3326-961	\$357.30
46I	1910	2	3322-302	165.15	3325-302	185.60	-	-
46J	1910	2	3322-304	165.15	3325-304	185.60	-	-
60I	1910	2	3322-320	165.15	3325-320	185.60	-	-
60J	1910	2	-	-	3325-322	185.60	-	-

## 14 x 2 x 5 – Recessed One Side 8 x 1"

GRIT/ HARDNESS	MAX RPM	CTN QTY	WHITE ALUMINUM OXIDE (TYPE WA)		PREMIUM BLUE ALUMINUM OXIDE (TYPE AZ)		SILICON CARBIDE (TYPE CG)		SYNTHETIC CERAMIC GRAIN (TYPE AS3)	
			ORDER NO.	PRICE EACH	ORDER NO.	PRICE EACH	ORDER NO.	PRICE EACH	CTN QTY	ORDER NO.
46H	1910	1	3322-400	\$179.75	3325-400	\$199.85	-	-	-	-
46I	1910	1	3322-402	179.75	3325-402	199.85	-	-	-	-
46J	1910	1	3322-404	179.75	3325-404	199.85	-	-	-	-
60I	1910	1	3322-420	179.75	-	-	-	-	-	-
60J	1910	1	-	-	3325-422	199.85	-	-	-	-
60K	1910	1	-	-	3325-424	199.85	-	-	-	-

\*Carton Qty. deduction not applicable

# Tool & Cutter Grinding Wheels



**Buy  
Ctn Qty  
Deduct  
20%**

**Vitrified Bonded Assortment of the Standard Shapes Most Commonly Used in Tool and Cutter Applications.**

**WA – White Aluminum Oxide**  
Friable grain for light grinding of all steels, particularly tool & die steels.

**CG – Green Silicon Carbide**  
Used for non-ferrous metals such as cemented carbides.

**AS3 – Synthetic Ceramic Blend**  
Features a blend of synthetic ceramic grain with PA and WA grains for optimum fracturing. Provides a continuous, sharp cutting action.

2

## 4/3 x 1-1/2 x 1-1/4 – Flaring Cup Wheel

GRIT/ HARDNESS	MAX RPM	CTN QTY	WHITE ALUMINUM OXIDE (TYPE WA)		SILICON CARBIDE (TYPE CG)		SYNTHETIC CERAMIC GRAIN (TYPE AS3)		
			ORDER NO.	PRICE EACH	ORDER NO.	PRICE EACH	CTN QTY	ORDER NO.	PRICE EACH
46I	6685	10	–	–	–	–	3	3103-820	\$47.80
46J	6685	10	3102-733	\$22.80	–	–	–	–	–
46K	6685	10	3102-734	22.80	–	–	–	–	–
60H	6685	10	3102-741†	10.40	–	–	–	–	–
60J	6685	10	3102-743	22.80	–	–	–	–	–
60K	6685	10	3102-744	22.80	–	–	3	3103-830	47.80
80K	6685	10	3102-750	22.80	–	–	–	–	–

† Limited Quantities



## 5/3-3/4 x 1-3/4 x 1-1/4 – Flaring Cup Wheel

GRIT/ HARDNESS	MAX RPM	CTN QTY	WHITE ALUMINUM OXIDE (TYPE WA)		SILICON CARBIDE (TYPE CG)		SYNTHETIC CERAMIC GRAIN (TYPE AS3)		
			ORDER NO.	PRICE EACH	ORDER NO.	PRICE EACH	CTN QTY	ORDER NO.	PRICE EACH
46H	5348	10	3102-802	\$34.10	–	–	–	–	–
46I	5348	10	3102-805	34.10	–	–	3	3103-880	\$63.40
46J	5348	10	3102-803	34.10	–	–	–	–	–
46K	5348	10	3102-804	34.10	–	–	–	–	–
60I	5348	10	3102-815	34.10	3103-120†	\$13.00	–	–	–
60J	5348	10	3102-813	34.10	–	–	3	3103-890	63.40
60K	5348	10	3102-814	34.10	–	–	–	–	–
80K	5348	10	3102-820	34.10	–	–	–	–	–



## 5 x 1-1/2 x 1-1/4 – Straight Cup Wheel

GRIT/ HARDNESS	MAX RPM	CTN QTY	WHITE ALUMINUM OXIDE (TYPE WA)		SILICON CARBIDE (TYPE CG)		SYNTHETIC CERAMIC GRAIN (TYPE AS3)		
			ORDER NO.	PRICE EACH	ORDER NO.	PRICE EACH	CTN QTY	ORDER NO.	PRICE EACH
46J	5348	10	3102-853	\$31.35	–	–	–	–	–
46K	5348	10	3102-854	31.35	–	–	–	–	–
60I	5348	10	–	–	3103-220†	\$11.85	–	–	–
60J	5348	10	3102-863	31.35	–	–	–	–	–
80K	5348	10	3102-870	31.35	–	–	–	–	–

† Limited Quantities



# Tool & Cutter Grinding Wheels



**Buy  
Ctn Qty  
Deduct  
20%**

## Vitrified Bonded Assortment of the Standard Shapes Most Commonly Used in Tool and Cutter Applications.

2

**WA – White Aluminum Oxide**  
Friable grain for light grinding of all steels, particularly tool & die steels.

**CG – Green Silicon Carbide**  
Used for non-ferrous metals such as cemented carbides.

**AS3 – Synthetic Ceramic Blend**  
Features a blend of synthetic ceramic grain with PA and WA grains for optimum fracturing. Provides a continuous, sharp cutting action.

### 6 x 1/2 x 1-1/4 – Dish Wheel

GRIT/ HARDNESS	MAX RPM	CTN QTY	WHITE ALUMINUM OXIDE (TYPE WA)		SILICON CARBIDE (TYPE CG)		SYNTHETIC CERAMIC GRAIN (TYPE AS3)		
			ORDER NO.	PRICE EACH	ORDER NO.	PRICE EACH	CTN QTY	ORDER NO.	PRICE EACH
46K	4456	10	3102-914	\$21.95	-	-	-	-	-
60J	4456	10	3102-923	21.95	-	-	-	-	-
60K	4456	10	3102-924	21.95	-	-	-	-	-



### 6 x 1 x 4 – Plate Mounted Wheels

GRIT/ HARDNESS	MAX RPM	CTN QTY	WHITE ALUMINUM OXIDE (TYPE WA)		SILICON CARBIDE (TYPE CG)		SYNTHETIC CERAMIC GRAIN (TYPE AS3)		
			ORDER NO.	PRICE EACH	ORDER NO.	PRICE EACH	CTN QTY	ORDER NO.	PRICE EACH
46K	3450	10	3103-960	\$55.25	-	-	-	-	-
60I	3450	10	-	-	3103-920	\$59.50	-	-	-
80I	3450	10	-	-	3103-930	59.50	-	-	-
100I	3450	10	-	-	3103-940	59.50	-	-	-
120I	3450	10	-	-	3103-950	59.50	-	-	-



### Vitrified Bond Silicon Carbide Dressing Sticks

For cleaning, dressing and reshaping vitrified bond grinding wheels.

SIZE	GRADE	ORDER NO.	PRICE EACH
6 x 1 x 1	24S	3132-998	\$3.17
8 x 1 x 1	24S	3132-999	4.23

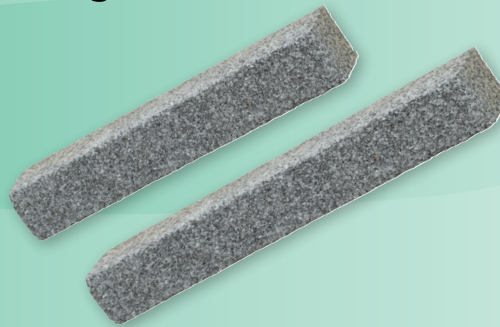

# Bench and Pedestal Wheels



2

## Vitrified Bonded Straight Wheels Used for Off-hand Tool Sharpening and General Purpose Bench Grinding Applications.



### A – Dark Aluminum Oxide

The most common of all grains. This grain is used for heavy duty general purpose work.

### CG – Green Silicon Carbide

Used for non-ferrous metals such as cemented carbides.

### 6 x 1/2 x 1 (H\*)

GRIT/ HARDNESS	MAX RPM	DARK ALUMINUM OXIDE (TYPE A)		SILICON CARBIDE (TYPE CG)	
		ORDER NO.	PRICE EACH	ORDER NO.	PRICE EACH
24Q	4456	3102-001†	\$3.30	–	–
360	4456	3102-002†	3.70	–	–
46M	4456	3102-003	16.30	–	–
60I	4456	–	–	3102-402	\$14.85
60M	4456	3102-004	16.30	–	–
80I	4456	–	–	3102-404	14.85
100I	4456	–	–	3102-406	14.85

† Limited Quantities

### 6 x 3/4 x 1 (H\*)

GRIT/ HARDNESS	MAX RPM	DARK ALUMINUM OXIDE (TYPE A)		SILICON CARBIDE (TYPE CG)	
		ORDER NO.	PRICE EACH	ORDER NO.	PRICE EACH
24Q	4456	3102-021†	\$8.15	–	–
360	4456	3102-022	14.05	–	–
46M	4456	3102-023	14.05	–	–
60I	4456	–	–	3102-422	\$17.60
60M	4456	3102-024	14.05	–	–
80I	4456	–	–	3102-424	17.60
80M	4456	3102-025	14.05	–	–
100I	4456	–	–	3102-426	17.60

### 6 x 1 x 1 (H\*)

GRIT/ HARDNESS	MAX RPM	DARK ALUMINUM OXIDE (TYPE A)		SILICON CARBIDE (TYPE CG)	
		ORDER NO.	PRICE EACH	ORDER NO.	PRICE EACH
24Q	4456	3102-041	\$16.20	–	–
360	4456	3102-042	16.20	–	–
46M	4456	3102-043	16.20	–	–
60I	4456	–	–	3102-442	\$19.40
60M	4456	3102-044	16.20	–	–
80I	4456	–	–	3102-444	19.40
80M	4456	3102-045	16.20	–	–
100I	4456	–	–	3102-446	19.40

### 7 x 3/4 x 1 (H\*)

GRIT/ HARDNESS	MAX RPM	DARK ALUMINUM OXIDE (TYPE A)		SILICON CARBIDE (TYPE CG)	
		ORDER NO.	PRICE EACH	ORDER NO.	PRICE EACH
24Q	3760	3102-061†	\$6.20	–	–
360	3760	3102-062†	5.70	–	–
60I	3760	–	–	3102-462	\$20.00
60M	3760	3102-064†	13.85	–	–
80I	3760	–	–	3102-464	20.00
100I	3760	–	–	3102-466	20.00

† Limited Quantities

### 7 x 1 x 1 (H\*)

GRIT/ HARDNESS	MAX RPM	DARK ALUMINUM OXIDE (TYPE A)		SILICON CARBIDE (TYPE CG)	
		ORDER NO.	PRICE EACH	ORDER NO.	PRICE EACH
24Q	3760	3102-081	\$19.20	–	–
360	3760	3102-082	19.20	–	–
46M	3760	3102-083	19.20	–	–
60I	3760	–	–	3102-482	\$23.65
60M	3760	3102-084	19.20	–	–
80I	3760	–	–	3102-484	23.65
80M	3760	3102-085	19.20	–	–
100I	3760	–	–	3102-486	23.65

### 8 x 1 x 1-1/4 (H<sup>4</sup>)

GRIT/ HARDNESS	MAX RPM	DARK ALUMINUM OXIDE (TYPE A)		SILICON CARBIDE (TYPE CG)	
		ORDER NO.	PRICE EACH	ORDER NO.	PRICE EACH
24Q	3760	3102-105	\$24.45	–	–
360	3760	3102-106	24.45	–	–
46M	3760	3102-107	24.45	–	–
60I	3760	–	–	3102-522	\$29.10
60M	3760	3102-108	24.45	–	–
80I	3760	–	–	3102-524	29.10
80M	3760	3102-109	24.45	–	–
100I	3760	–	–	3102-526	29.10

H\*: 1" Hole, Installed Telescopic Bushings for 3/4", 5/8", and 1/2" arbors

H<sup>2</sup>: 1-1/4" Hole, Installed Telescopic Bushings for 1" and 3/4" arbors

H<sup>3</sup>: 1-1/2" Hole, Installed Telescopic Bushings for 1-1/4" and 1" arbors

H<sup>4</sup>: 1-1/4" Hole, Installed Telescopic Bushings for 1", 3/4", 5/8", and 1/2" arbors



# Bench and Pedestal Wheels



2



## Vitrified Bonded Straight Wheels Used for Off-hand Tool Sharpening and General Purpose Bench Grinding Applications

### 10 x 1 x 1-1/4" (H<sup>2</sup>)

GRIT/ HARDNESS	MAX RPM	DARK ALUMINUM OXIDE (TYPE A)		SILICON CARBIDE (TYPE CG)	
		ORDER NO.	PRICE EACH	ORDER NO.	PRICE EACH
24Q	2483	3102-141	\$48.05	-	-
360	2483	3102-142	48.05	-	-
46M	2483	3102-143	48.05	-	-
60I	2483	-	-	3102-542	\$59.50
60M	2483	3102-144	48.05	-	-
80I	2483	-	-	3102-544	59.50
80M	2483	3102-145	48.05	-	-
100I	2483	-	-	3102-546	59.50

### 10 x 1-1/2 x 1-1/4" (H<sup>2</sup>)

GRIT/ HARDNESS	MAX RPM	DARK ALUMINUM OXIDE (TYPE A)		SILICON CARBIDE (TYPE CG)	
		ORDER NO.	PRICE EACH	ORDER NO.	PRICE EACH
24Q	2483	3102-161	\$61.75	-	-
360	2483	3102-162	61.75	-	-
46M	2483	3102-163	61.75	-	-
60I	2483	-	-	3102-562	\$69.00
60M	2483	3102-164	61.75	-	-
80I	2483	-	-	3102-564	69.00
80M	2483	3102-165†	61.75	-	-
100I	2483	-	-	3102-566	37.80

† Limited Quantities

### 12 x 1 x 1-1/4" (H<sup>2</sup>)

GRIT/ HARDNESS	MAX RPM	DARK ALUMINUM OXIDE (TYPE WA)		SILICON CARBIDE (TYPE CG)	
		ORDER NO.	PRICE EACH	ORDER NO.	PRICE EACH
24Q	2220	3102-181	\$75.50	-	-
46M	2220	3102-183	75.50	-	-
60I	2220	-	-	3102-582	\$85.30
60M	2220	3102-184	75.50	-	-

### 12 x 1-1/2 x 1-1/4" (H<sup>2</sup>)

GRIT/ HARDNESS	MAX RPM	DARK ALUMINUM OXIDE (TYPE WA)		SILICON CARBIDE (TYPE CG)	
		ORDER NO.	PRICE EACH	ORDER NO.	PRICE EACH
360	2220	3102-206	\$94.60	-	-
46M	2220	3102-207	94.60	-	-
60I	2220	-	-	3102-602	\$108.80
60M	2220	3102-208	94.60	-	-
80I	2220	-	-	3102-604	108.80

### 12 x 2 x 1-1/2" (H<sup>3</sup>)

GRIT/ HARDNESS	MAX RPM	DARK ALUMINUM OXIDE (TYPE WA)		SILICON CARBIDE (TYPE CG)	
		ORDER NO.	PRICE EACH	ORDER NO.	PRICE EACH
24Q	2220	3102-221	\$102.20	-	-
360	2220	3102-222	102.20	-	-
46M	2220	3102-223	102.20	-	-
60I	2220	-	-	3102-622	\$122.40
60M	2220	3102-224	102.20	-	-
80I	2220	-	-	3102-624	122.40
80M	2220	3102-225	102.20	-	-
100I	2220	-	-	3102-626	122.40

### 14 x 2 x 1-1/4" To 1-1/2" (H<sup>3</sup>)

GRIT/ HARDNESS	MAX RPM	DARK ALUMINUM OXIDE (TYPE WA)		SILICON CARBIDE (TYPE CG)	
		ORDER NO.	PRICE EACH	ORDER NO.	PRICE EACH
24Q	1910	3102-271	\$153.90	-	-
360	1910	3102-272	153.90	-	-
46M	1910	3102-273	153.90	-	-
60I	1910	-	-	3102-642	\$196.40
60M	1910	3102-274	153.90	-	-
80I	1910	-	-	3102-644	196.40

### 16 x 2 x 1-1/2" (H<sup>3</sup>)

GRIT/ HARDNESS	MAX RPM	DARK ALUMINUM OXIDE (TYPE WA)		SILICON CARBIDE (TYPE CG)	
		ORDER NO.	PRICE EACH	ORDER NO.	PRICE EACH
24Q	1550	3102-301	\$254.75	-	-
360	1550	3102-302	264.65	-	-

### 18 x 3 x 1-1/2" (H<sup>3</sup>)

GRIT/ HARDNESS	MAX RPM	DARK ALUMINUM OXIDE (TYPE WA)		SILICON CARBIDE (TYPE CG)	
		ORDER NO.	PRICE EACH	ORDER NO.	PRICE EACH
360	1485	3102-322	\$420.75	-	-
54M	1485	3102-324	420.75	-	-

H\*: 1" Hole, Installed Telescopic Bushings for 3/4", 5/8", and 1/2" arbors

H<sup>2</sup>: 1-1/4" Hole, Installed Telescopic Bushings for 1" and 3/4" arbors

H<sup>3</sup>: 1-1/2" Hole, Installed Telescopic Bushings for 1-1/4" and 1" arbors

H<sup>4</sup>: 1-1/4" Hole, Installed Telescopic Bushings for 1", 3/4", 5/8", and 1/2" arbors

# Mattison-Thompson Type



## Large 20 Inch Diameter Surface Grinding Wheels For Horizontal Spindle, Rotary and Reciprocating Tables.

### 83A – Friable Full Premium Aluminum Oxide

Friable grain for fast stock removal.

The free cutting open structure is ideal for all tool steels.

V-18 – Normal structures. V-18P – Induced open porosity.

### 73C – Silicon Carbide

For non-ferrous metals, gray iron.

### 91A – Semi-Friable, Mixed Aluminum Oxide

Provides a continuous, sharp cutting action. A mixture of WA and A abrasives.

Recommended for general purpose work and light stock removal.

### AS3 – Synthetic Ceramic Blend

Features a blend of synthetic ceramic grain with PA and WA grains for optimum fracturing.



1

**Buy  
Ctn Qty  
(Where shown)  
Deduct  
10%**

### 20 x 1 x 8

GRAIN	GRIT/ BOND	MAX RPM	ORDER NO.	PRICE EACH
83A	46H8 V-18	1241	3280-402*	\$176.95
83A	60J8 V-18	1241	3280-404*	176.95

\*CARTON QTY.= 3

### 20 x 2 x 10

GRAIN	GRIT/ BOND	MAX RPM	ORDER NO.	PRICE EACH
83A	36J8 V-18	1241	3280-450*	\$263.30
83A	46H8 V-18	1241	3280-452*	263.30
83A	60J8 V-18	1241	3280-454*	263.30
83A	46G+ V-18P	1241	3280-456*	263.30

\*CARTON QTY.= 2

### 20 x 1-1/2 x 8

Recessed 1/5 11-1/2 x 1/2"

GRAIN	GRIT/ BOND	MAX RPM	ORDER NO.	PRICE EACH
83A	46H8 V-18	1241	3280-422*	\$234.70

### 20 x 3 x 8

Recessed 2/5 11-1/2 x 1/2"

GRAIN	GRIT/ BOND	MAX RPM	ORDER NO.	PRICE EACH
83A	46H8 V-18	1241	3280-462*	\$403.40
83A	36J/K V-18P	1241	3280-464*	403.40
83A	46D V-18P	1241	3280-465*	403.40
83A	46G+ V-18P	1241	3280-468*	403.40
91A	46I8 V-18	1241	3280-460*	394.15
73C	46I8 V-X	1241	3280-606*	537.05

\*CARTON QTY.= 2

### 20 x 2 x 8

Recessed 2/5 11-1/2 x 1/2"

GRAIN	GRIT/ BOND	MAX RPM	ORDER NO.	PRICE EACH
83A	46H8 V-18	1241	3280-442*	\$297.35
83A	60J8 V-18	1241	3280-446*	297.35
83A	46G+ V-18P	1241	3280-449*	297.35
91A	46I8 V-18	1241	3280-440*	285.70

\*CARTON QTY.= 2

### 20 x 3 x 10

Recessed 1/5 12-1/2 x 5/8"  
O/S 12-1/2 x 1"

GRAIN	GRIT/ BOND	MAX RPM	ORDER NO.	PRICE EACH
83A	46H8 V-18	1241	3280-472*	\$366.40
83A	60J8 V-18	1241	3280-473*	366.40
83A	36J/K V-18P	1241	3280-474*	366.40
83A	46G+ V-18P	1241	3280-478*	366.40
91A	46I8 V-18	1241	3280-470*	366.40
73C	46I8 V-X	1241	3280-608*	486.60
AS3	46H V-CER	1241	3280-664*	718.40

\*CARTON QTY.= 2

### 20 x 4 x 8

Recessed 2/5 11-1/2 x 1/2"

GRAIN	GRIT/ BOND	MAX RPM	ORDER NO.	PRICE EACH
83A	46H8 V-18	1241	3280-482	\$475.50

### 20 x 4 x 10

Recessed 1/5 12-1/2 x 7/8", O/S 12-1/2 x 1-1/4"

GRAIN	GRIT/ BOND	MAX RPM	ORDER NO.	PRICE EACH
83A	46H8 V-18	1241	3280-492	\$428.95
83A	46G+ V-18P	1241	3280-498	428.95
91A	46I8 V-18	1241	3280-490	400.00

### 20 x 6 x 10

Recessed 1/5 12-1/2 x 1"  
O/S 12-1/2 x 2"

GRAIN	GRIT/ BOND	MAX RPM	ORDER NO.	PRICE EACH
83A	46H8 V-18	1241	3280-502	\$555.00
83A	36J/K V-18P	1241	3280-504	555.00
83A	46G+ V-18P	1241	3280-508	538.85
91A	46I8 V-18	1241	3280-500	528.60
AS3	46H V-CER	1241	3280-674	1026.30

### 20 x 6 x 12

Recessed 2/5 14-1/4 x 1"

GRAIN	GRIT/ BOND	MAX RPM	ORDER NO.	PRICE EACH
83A	46H8 V-18	1241	3280-512	\$567.15
83A	46G+ V-18P	1241	3280-518	550.65

# Centerless & Cylindrical Wheels



## 12" Through 24" Diameter

Centerless & Cylindrical Wheels each have accurate toleranced inside linings to protect spindles. Manufactured with varying hardness to assure consistent grindability throughout.

### 94A – Aluminum Oxide

Very durable self-dressing grain.

### 72C – Silicon Carbide

For non-ferrous metals.

### PA – Pink Aluminum Oxide

Excellent for pre-hardened carbon steels.

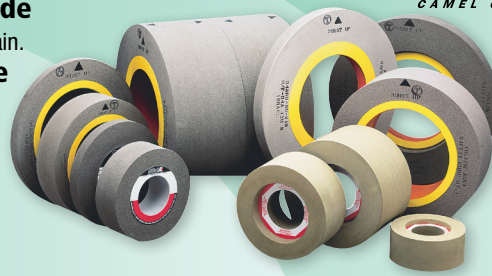

**Buy Ctn Qty (Where shown) Deduct 10%**

### 14 x 1 x 5 – No Recess

GRAIN	GRIT	MAX RPM	ORDER NO.	PRICE EACH
94A	54-K	1910	3327-012*	\$80.20
94A	80-M	1910	3327-020*	80.20

\*CARTON QTY.= 2

### 14 x 1-1/4 x 5 – No Recess

GRAIN	GRIT	MAX RPM	ORDER NO.	PRICE EACH
94A	54-K	1910	3327-032*	\$100.40

\*CARTON QTY.= 2

### 14 x 1-1/2 x 5 – Rec 1/5 8 X 1/2"

GRAIN	GRIT	MAX RPM	ORDER NO.	PRICE EACH
94A	54-K	1910	3327-052*	\$122.60
94A	80-M	1910	3327-060*	122.60

\*CARTON QTY.= 2

### 14 x 2 x 5 – Rec 1/5 8 X 1"

GRAIN	GRIT	MAX RPM	ORDER NO.	PRICE EACH
94A	54-K	1910	3327-072	\$138.85
94A	60-L	1910	3327-076	138.85
94A	80-M	1910	3327-080	138.85

### 16 x 1 x 5 – No Recess

GRAIN	GRIT	MAX RPM	ORDER NO.	PRICE EACH
94A	60-L	1671	3327-096	\$100.65
94A	80-M	1671	3327-100	100.65

### 16 x 1-1/2 x 5 – No Recess

GRAIN	GRIT	MAX RPM	ORDER NO.	PRICE EACH
94A	60-L	1671	3327-116	\$124.60
94A	80-M	1671	3327-120	124.60

### 16 x 2 x 5 – No Recess

GRAIN	GRIT	MAX RPM	ORDER NO.	PRICE EACH
94A	60-L	1671	3327-156	\$157.90
94A	80-M	1671	3327-160	157.90

### 16 x 1-1/2 x 8 – No Recess

GRAIN	GRIT	MAX RPM	ORDER NO.	PRICE EACH
94A	54-K	1671	3327-212	\$119.80
94A	80-M	1671	3327-220	119.80

### 16 x 2 x 8 – No Recess

GRAIN	GRIT	MAX RPM	ORDER NO.	PRICE EACH
94A	60-L5	1671	3327-236	\$144.70

### 16 x 4 x 10 – No Recess

GRAIN	GRIT	MAX RPM	ORDER NO.	PRICE EACH
94A	60-L	1671	3327-256	\$251.10
94A	80-L	1671	3327-260	251.10

### 20 x 1 x 12 – No Recess

GRAIN	GRIT	MAX RPM	ORDER NO.	PRICE EACH
94A	60-M	1623	3327-280*	\$144.55
94A	80-O	1623	3327-304*	144.55

\*CARTON QTY.= 3

### 20 x 2 x 12 – No Recess

GRAIN	GRIT	MAX RPM	ORDER NO.	PRICE EACH
94A	60-K	1623	3327-316*	\$226.60
94A	60-L	1623	3327-318*	226.60
94A	60-M	1623	3327-320*	226.60
94A	80-P	1623	3327-336*	226.60

HARD SIDE

94A	80-N/120-S	1623	3327-330*	244.90
-----	------------	------	-----------	--------

\*CARTON QTY.= 2

### 20 x 2-1/2 x 12 – No Recess

GRAIN	GRIT	MAX RPM	ORDER NO.	PRICE EACH
HARD SIDE				
94A	80-N/120-S	1623	3327-360*	\$296.95

\*CARTON QTY.= 2

### 20 x 3 x 12 – No Recess

GRAIN	GRIT	MAX RPM	ORDER NO.	PRICE EACH
94A	60-K	1623	3327-376*	\$308.85

\*CARTON QTY.= 2

### 20 x 4 x 12 – No Recess

GRAIN	GRIT	MAX RPM	ORDER NO.	PRICE EACH
94A	60-K	1623	3327-436	\$342.10
94A	60-L	1623	3327-438	342.10
94A	80-M	1623	3327-448	342.10
94A	80-P	1623	3327-458	342.10

HARD SIDE

94A	80-N/120-S	1623	3327-452	369.75
-----	------------	------	----------	--------

### 20 x 6 x 12 – No Recess

GRAIN	GRIT	MAX RPM	ORDER NO.	PRICE EACH
72C	60-L	1623	3327-470	\$634.85
94A	60-K	1623	3327-476	468.95
94A	60-L	1623	3327-478	468.95
94A	60-M	1623	3327-480	468.95
94A	80-J	1623	3327-484	468.95
94A	80-M	1623	3327-488	468.95

HARD SIDE

94A	80-N/120-S	1623	3327-492	522.05
-----	------------	------	----------	--------

### 20 x 8 x 12 – No Recess

GRAIN	GRIT	MAX RPM	ORDER NO.	PRICE EACH
94A	54-J	1623	3327-512	596.80
94A	60-K	1623	3327-516	596.80
94A	60-L	1623	3327-518	596.80
94A	60-M	1623	3327-520	596.80
94A	80-J	1623	3327-524	596.80
94A	80-L	1623	3327-526	596.80
94A	80-M	1623	3327-528	596.80
94A	80-O	1623	3327-536	596.80

HARD SIDE

94A	80-N/120-S	1623	3327-532	661.75
-----	------------	------	----------	--------

# Centerless & Cylindrical Wheels

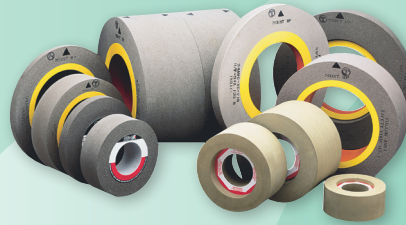

1  
**Buy Ctn Qty**  
 (Where shown)  
**Deduct 10%**

## 24 x 2 x 12 – No Recess

GRAIN	GRIT	MAX RPM	ORDER NO.	PRICE EACH
94A	60-K	1353	3327-656*	\$374.75
HARD SIDE				
94A	80-N/120-S	1353	3327-672*	416.30

\*CARTON QTY.= 2

## 24 x 4 x 12 – No Recess

GRAIN	GRIT	MAX RPM	ORDER NO.	PRICE EACH
94A	60-K	1353	3327-816	\$541.20
94A	60-L	1353	3327-818	541.20
94A	80-M	1353	3327-830	541.20
HARD SIDE				
94A	80-N/120-S	1353	3327-834	601.25

## 24 x 8 x 12 – No Recess

GRAIN	GRIT	MAX RPM	ORDER NO.	PRICE EACH
72C	60-L6	1353	3327-900	\$1163.25
94A	60-K5	1353	3327-916	928.45
94A	60-L5	1353	3327-918	928.45
94A	60-M6	1353	3327-920	928.45
94A	80-J5	1353	3327-924	928.45
94A	80-L5	1353	3327-928	928.45

## 24 x 2-1/2 x 12 – No Recess

GRAIN	GRIT	MAX RPM	ORDER NO.	PRICE EACH
HARD SIDE				
94A	80-N/120-S	1353	3327-712*	\$464.95

\*CARTON QTY.= 2

## 24 x 6 x 12 – No Recess

GRAIN	GRIT	MAX RPM	ORDER NO.	PRICE EACH
94A	60-K	1353	3327-866	\$732.80
94A	60-L	1353	3327-868	732.80
94A	80-J	1353	3327-874	732.80
HARD SIDE				
94A	80-N/120-S	1353	3327-884	807.25

## 24 x 10 x 12 – No Recess

GRAIN	GRIT	MAX RPM	ORDER NO.	PRICE EACH
94A	60-K5	1353	3327-956	\$1225.40

## 24 x 3 x 12 – No Recess

GRAIN	GRIT	MAX RPM	ORDER NO.	PRICE EACH
94A	60-K	1353	3327-736	\$412.55

## 24 x 20 x 12 – No Recess

GRAIN	GRIT	MAX RPM	ORDER NO.	PRICE EACH
94A	60-K5	1353	3327-986	\$2546.40
94A	60-M6	1353	3327-990	2546.40

# Feed/Regulating Wheels 1

**Aluminum Oxide – Rubber Bonded For All Centerless Grinding Machines**  
**Isostatic process assures perfect gripping with standard A-80-R2-RX grade**

	MAX RPM	ORDER NO.	PRICE EACH
9 x 4 x 4 R 2/S 5-1/2 x 5/8"	1020	3329-140	158.80
12 x 1 x 5	800	3329-410	83.80
12 x 2 x 5	800	3329-420	145.20
12 x 2-1/2 x 5	800	3329-425	199.30
12 x 4 x 5 R 2/S 7-1/2 x 1/2"	800	3329-442	289.10

	MAX RPM	ORDER NO.	PRICE EACH
12 x 6 x 5 R 1/S 7-1/2 x 1/2" O/S 7-1/2 x 1-1/2"	800	3329-462	\$442.30
12 x 6 x 5 R 2/S 7-1/2 x 1-1/2"	800	3329-464	442.30
12 x 8 x 5 R 1/S 7-1/2 x 1-1/2"	800	3329-480	561.30
12 x 8 x 5 R 1/S 7-1/2 x 1-1/2" O/S 7-1/2 x 2-1/2"	800	3329-482	561.30

	MAX RPM	ORDER NO.	PRICE EACH
14 x 8 x 5 R 1/S 8 x 1-1/2" O/S 8 x 2"	650	3329-682	\$711.00
14 x 8 x 5 R 1/S 8 x 1-1/2" O/S 8 x 2-1/2"	650	3329-684	750.15
14 x 20 x 6 R 2/S 8-1/2 x 1-1/2"	650	3329-804	1854.85

# Mounted Points

## Group "A" Special Shapes

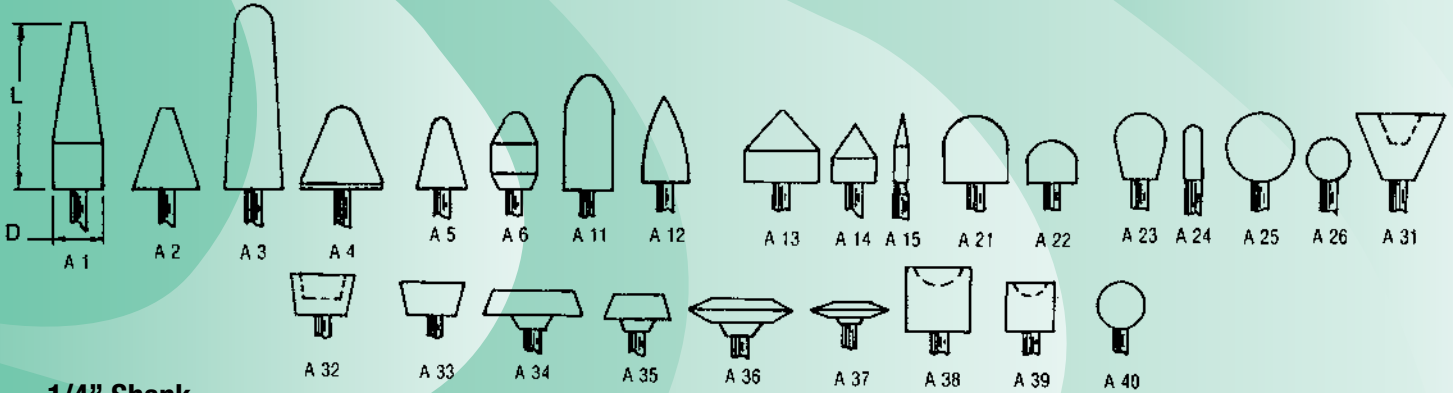

### 1/4" Shank

SHAPE NO.	SIZE DIAM.	LGTH.	ORDER NO.	PRICE EACH
A1	3/4"	2-1/2"	3133-001	\$3.80
A2	1"	1-1/4"	3133-002	2.30
A3	1"	2-3/4"	3133-003	4.10
A4	1-1/4"	1-1/4"	3133-004	2.60
A5	3/4"	1-1/8"	3133-005	2.20
A6	3/4"	1-1/8"	3133-006	2.20
A11	7/8"	2"	3133-011	2.80
A12	11/16"	1-1/4"	3133-012	2.20
A13	1-1/8"	1-1/8"	3133-013	2.60

SHAPE NO.	SIZE DIAM.	LGTH.	ORDER NO.	PRICE EACH
A14	11/16"	7/8"	3133-014	\$1.65
A15	1/4"	1-1/16"	3133-015	2.10
A21	1"	1"	3133-021	1.80
A22	3/4"	5/8"	3133-022	1.60
A23	3/4"	1"	3133-023	1.65
A24	1/4"	3/4"	3133-024	1.50
A25	1"	1"	3133-025	1.80
A26	5/8"	5/8"	3133-026	1.60
A31	1-3/8"	1"	3133-031	2.20

SHAPE NO.	SIZE DIAM.	LGTH.	ORDER NO.	PRICE EACH
A32	1"	5/8"	3133-032	\$1.65
A33	1"	1/2"	3133-033	1.60
A34	1-1/2"	3/8"	3133-034	1.90
A35	1"	3/8"	3133-035	1.60
A36	1-5/8"	3/8"	3133-036	2.20
A37	1-1/4"	1/4"	3133-037	1.65
A38	1"	1"	3133-038	1.50
A39	3/4"	3/4"	3133-039	1.25
A40	3/4"	3/4"	3133-040	1.60

## Group "W" Plain Shapes



### 1/8" X 1-1/2" Shank

SHAPE NO.	SIZE DIAM.	LGTH.	ORDER NO.	PRICE EACH
W141	3/32	5/32	3133-141	\$1.10
W142	3/32	1/4	3133-142	1.10
W143	1/8	1/8	3133-143	1.10
W144	1/8	1/4	3133-144	1.10
W145	1/8	3/8	3133-145	1.20
W146	1/8	1/2	3133-146	1.20
W149	5/32	1/4	3133-149	1.10
W150	3/16	1/16	3133-150†	0.70
W151	3/16	1/8	3133-151	1.10
W152	3/16	1/4	3133-152	1.10
W153	3/16	3/8	3133-153	1.20
W154	3/16	1/2	3133-154	1.20
W155	13/64	1/4	3133-155†	0.70
W157	1/4	1/16	3133-157	1.10
W158	1/4	1/8	3133-158	1.10
W159	1/4	3/16	3133-159	1.10
W160	1/4	1/4	3133-160	1.10
W161	1/4	5/16	3133-161	1.20
W162	1/4	3/8	3133-162	1.20
W163	1/4	1/2	3133-163	1.20
W164	1/4	3/4	3133-164	1.25
W165	5/16	1/16	3133-165	1.10
W166	5/16	1/8	3133-166	1.10
W167	5/16	1/4	3133-167	1.10
W168	5/16	5/16	3133-168	1.20
W169	5/16	3/8	3133-169	1.20
W170	5/16	1/2	3133-170	1.20
W171	5/16	3/4	3133-171	1.25
W172	3/8	1/16	3133-172	1.10
W173	3/8	1/8	3133-173	1.10
W174	3/8	1/4	3133-174	1.10

SHAPE NO.	SIZE DIAM.	LGTH.	ORDER NO.	PRICE EACH
W175	3/8	3/8	3133-175	\$1.20
W176	3/8	1/2	3133-176	1.20
W177	3/8	3/4	3133-177	1.25
W178	3/8	1	3133-178	1.35
W179	3/8	1-1/4	3133-179†	1.10
W181	1/2	1/16	3133-181	1.10
W182	1/2	1/8	3133-182	1.10
W183	1/2	1/4	3133-183	1.10
W184	1/2	3/8	3133-184	1.20
W185	1/2	1/2	3133-185	1.20
W186	1/2	3/4	3133-186	1.25
W187	1/2	1	3133-187	1.35
W190	5/8	1/16	3133-190	1.20
W191	5/8	1/8	3133-191	1.20
W192	5/8	1/4	3133-192	1.20
W193	5/8	3/8	3133-193	1.25
W194	5/8	1/2	3133-194	1.25
W195	5/8	3/4	3133-195	1.35
W199	3/4	1/16	3133-199	1.20
W200	3/4	1/8	3133-200	1.20
W201	3/4	1/4	3133-201	1.20
W202	3/4	3/8	3133-202	1.25
W203	3/4	1/2	3133-203	1.25
W204	3/4	3/4	3133-204	1.35
W210	7/8	1/16	3133-210	1.25
W211	7/8	1/8	3133-211	1.25
W212	7/8	1/4	3133-212	1.25
W213	7/8	3/8	3133-213	1.35
W214	15/16	1/4	3133-214	1.25
W215	1	1/8	3133-215	1.25
W216	1	1/4	3133-216	1.25

### 1/4" X 1-1/2" Shank

SHAPE NO.	SIZE DIAM.	LGTH.	ORDER NO.	PRICE EACH
W178	3/8	1	3133-378	\$1.35
W187	1/2	1	3133-387	1.35
W188	1/2	1-1/2	3133-188	2.05
W189	1/2	2	3133-189	2.60
W194	5/8	1/2	3133-394	1.25
W195	5/8	3/4	3133-395	1.35
W196	5/8	1	3133-196	1.50
W197	5/8	2	3133-197	2.70
W198	5/8	2-1/2	3133-198	3.35
W204	3/4	3/4	3133-404	1.35
W205	3/4	1	3133-205	1.50
W206	3/4	1-1/4	3133-206	1.80
W207	3/4	1-1/2	3133-207	2.15
W208	3/4	2	3133-208	2.70
W209	3/4	2-1/2	3133-209	3.35
W213	7/8	3/8	3133-413	1.35
W217	1	3/8	3133-217	1.35
W218	1	1/2	3133-218	1.35
W219	1	3/4	3133-219	1.50
W220	1	1	3133-220	1.60
W221	1	1-1/2	3133-221	2.25
W222	1	2	3133-222	2.80
W223	1	2-1/2	3133-223	3.45
W224	1	3	3133-224	2.55
W225	1-1/4	1/4	3133-225	1.50
W226	1-1/4	3/8	3133-226	1.60
W227	1-1/4	1/2	3133-227	1.60
W228	1-1/4	3/4	3133-228	1.70
W229	1-1/4	1	3133-229	1.95
W230	1-1/4	1-1/4	3133-230	2.25
W231	1-1/4	1-1/2	3133-231	2.70
W232	1-1/4	2	3133-232	3.35
W235	1-1/2	1/4	3133-235	1.60
W236	1-1/2	1/2	3133-236	1.70
W237	1-1/2	1	3133-237	2.05
W238	1-1/2	1-1/2	3133-238	2.80
W239	1-1/2	2	3133-239	3.45
W242	2	1	3133-242	2.60
W243	2	1-1/2	3133-243	3.45
W244	2	2	3133-244	4.30
W245	2	2-1/2	3133-245†	0.00

† Limited Quantities

# Mounted Points

## Group "B" Special Shapes

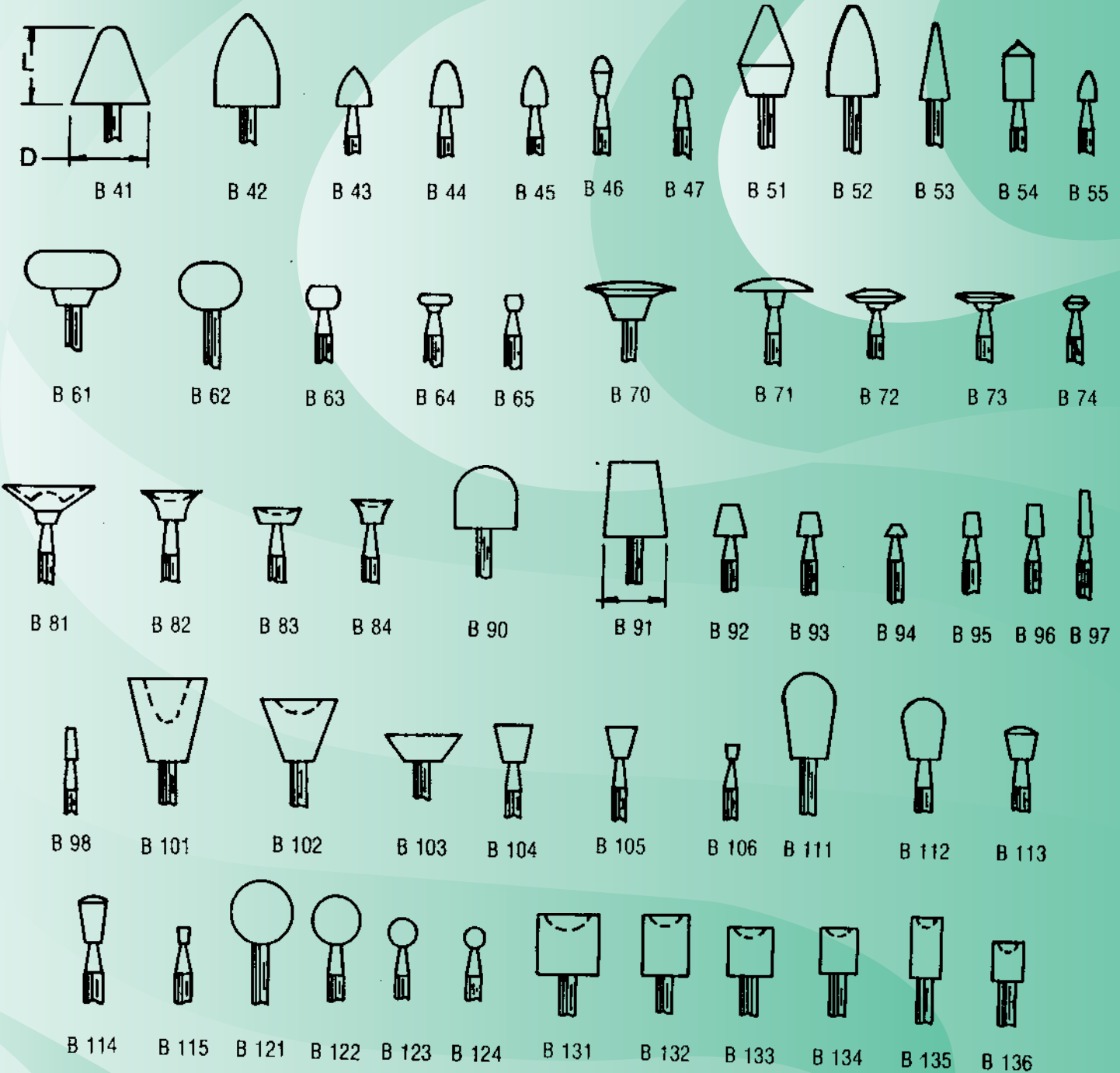

### 1/8' Shank

SHAPE NO.	SIZE DIAM.	LGTH.	ORDER NO.	PRICE EACH	SHAPE NO.	SIZE DIAM.	LGTH.	ORDER NO.	PRICE EACH	SHAPE NO.	SIZE DIAM.	LGTH.	ORDER NO.	PRICE EACH	SHAPE NO.	SIZE DIAM.	LGTH.	ORDER NO.	PRICE EACH
B41	5/8"	5/8"	3133-041	\$1.60	B63	1/4"	3/16"	3133-063	\$1.25	B92	1/4"	1/4"	3133-092	\$1.25	B112	3/8"	1/2"	3133-112	\$1.40
B42	1/2"	3/4"	3133-042	1.50	B64	1/4"	1/16"	3133-064	1.25	B93	3/16"	3/16"	3133-093	1.25	B113	1/4"	1/4"	3133-113	1.25
B43	1/4"	5/16"	3133-043	1.40	B65	1/8"	1/8"	3133-065	1.25	B94	11/64"	3/32"	3133-094	1.25	B114	7/32"	3/8"	3133-114	1.40
B44	7/32"	5/8"	3133-044	1.40	B70	3/4"	1/8"	3133-070	1.40	B95	1/8"	3/16"	3133-095	1.25	B115	3/32"	1/8"	3133-115	1.25
B45	3/16"	5/16"	3133-045	1.40	B71	5/8"	3/32"	3133-071	1.40	B96	1/8"	1/4"	3133-096	1.25	B121	1/2"	1/2"	3133-121	1.40
B46	1/8"	5/16"	3133-046	1.40	B72	1/2"	1/8"	3133-072	1.25	B97	1/8"	3/8"	3133-097	1.40	B122	3/8"	3/8"	3133-122	1.40
B47	1/8"	5/32"	3133-047	1.25	B73	1/2"	1/8"	3133-073	1.25	B98	3/32"	1/4"	3133-098	1.25	B123	3/16"	3/16"	3133-123	1.25
B51	7/16"	3/4"	3133-051	1.50	B74	7/32"	3/32"	3133-074	1.25	B101	5/8"	11/16"	3133-101	1.60	B124	1/8"	1/8"	3133-124	1.25
B52	3/8"	3/4"	3133-052	1.50	B81	3/4"	3/16"	3133-081	1.40	B102	5/8"	1/2"	3133-102	1.50	B131	1/2"	1/2"	3133-131	1.10
B53	1/4"	5/8"	3133-053	1.50	B82	1/2"	1/4"	3133-082	1.25	B103	5/8"	3/16"	3133-103	1.40	B132	3/8"	1/2"	3133-132	1.10
B54	1/4"	1/2"	3133-054	1.40	B83	3/8"	3/16"	3133-083	1.25	B104	5/16"	3/8"	3133-104	1.40	B133	3/8"	3/8"	3133-133	1.10
B55	1/8"	1/4"	3133-055	1.25	B84	5/16"	3/16"	3133-084	1.25	B105	1/4"	1/4"	3133-105	1.25	B134	5/16"	3/8"	3133-134	1.10
B61	3/4"	5/16"	3133-061	1.50	B89	1/2"	1/2"	3133-090	1.40	B106	1/8"	7/64"	3133-106	1.25	B135	1/4"	1/2"	3133-135	1.10
B62	3/8"	1"	3133-062	1.40	B91	1/2"	5/8"	3133-091	1.50	B111	7/16"	11/16"	3133-111	1.50	B136	1/4"	5/16"	3133-136	1.10

# Diamond Tools

## For Surface Grinders – 6 Inch Overall Length



**Preferred Grade— Made in USA**  
For machine or hand dressing of all wheels. Designed for longer tool life.

**Economy Grade**  
For general purpose dressing and truing of soft wheels.

RECOMMENDED DIAMOND SIZE			
WHEEL FACE	CARAT WT.	WHEEL FACE	CARAT WT.
1/4	1/4	2	1-1/2
1/2	1/3	3	1-3/4
3/4	1/2	3-1/2	2
1	3/4	4	2-1/2
1-1/4	1	6	3
1-1/2	1-1/4	8 and up	3-1/2

## Economy - Super Value 1/4 Carat - Single Point



SHANK SIZE	ORDER NO.	PRICE
3/8 x 2	3131-040	\$4.55
3/8 x 3	3131-045	4.55
7/16 x 2	3131-080	4.55
7/16 x 3	3131-085	4.55

## Convex & Concave Radii Forming Tools MR and FR Series

Designed to form convex and concave radii on small diameter grinding wheels. 3/8" x 2" Shanks.



### MR Series Convex Radii

TOOL NO.	RADIUS	ORDER NO.	PRICE
MR-2	.020-.125	3131-582	\$12.45
MR-4	.125-.250	3131-584	14.00
MR-6	.250 up	3131-586	17.20

### FR Series Concave Radii

TOOL NO.	RADIUS	ORDER NO.	PRICE
FR-10	.010	3131-550	\$10.00
FR-15	.015	3131-555	10.00
FR-20	.020	3131-560	10.00
FR-32	.032	3131-565	11.30
FR-62	.062	3131-570	12.90
FR-125	.125	3131-575	12.90

ECONOMY				PREFERRED – USA	
SHANK SIZE	CARAT SIZE	ORDER NO.	PRICE	ORDER NO.	PRICE
3/8	1/4	3131-311	\$ 4.30	3131-341	\$18.50
3/8	1/3	3131-312	6.35	3131-342	22.00
3/8	1/2	3131-313	8.70	3131-343	27.10
3/8	3/4	3131-314	12.95	3131-344	39.00
3/8	1	3131-315	17.20	-	-
3/8	1-1/2	3131-316	25.80	-	-
3/8	2	3131-317	34.20	-	-
3/8	3	3131-318	48.55	-	-
7/16	1/4	3131-321	4.30	3131-361	18.50
7/16	1/3	3131-322	6.35	3131-362	22.00
7/16	1/2	3131-323	8.70	3131-363	27.10
7/16	3/4	3131-324	12.95	3131-364	39.00
7/16	1	3131-325	17.20	-	-
7/16	1-1/2	3131-326	25.80	-	-
7/16	2	3131-327	34.20	-	-
7/16	3	3131-328	48.55	-	-
1/2	1/4	3131-331	4.30	-	-
1/2	1/3	3131-332	6.35	-	-
1/2	1/2	3131-333	8.70	-	-
1/2	3/4	3131-334	12.95	-	-
1/2	1	3131-335	17.20	-	-
1/2	1-1/2	3131-336	25.80	-	-
1/2	2	3131-337	34.20	-	-
1/2	3	3131-338	48.55	-	-

## Phonopoint Diamond Dressing Tools

Small cone pointed tools used for precision form dressing.



SHANK SIZE	60 DEG		75 DEG		90 DEG	
	ORDER NO.	PRICE	ORDER NO.	PRICE	ORDER NO.	PRICE
1/8 x 1"	3131-536	\$6.20	3131-541	\$5.60	3131-546	\$5.10
3/16 x 1"	3131-537	6.60	3131-542	6.00	3131-547	5.40
1/4 x 1-1/2"	3131-539	7.00	3131-544	6.30	3131-549	5.50

## Coned Radius Dressers

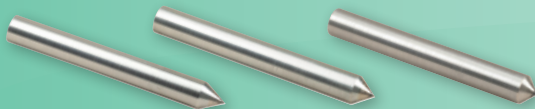

A precision shaped tool used for intricate form & radius dressing.

CARAT SIZE	INCLUDED ANGLE	3/8 x 2-1/2 SHANK		7/16 x 2-1/2 SHANK	
		ORDER NO.	PRICE	ORDER NO.	PRICE
1/4	60 DEG	3131-461	\$44.00	3131-481	\$44.00
1/4	75 DEG	3131-462	40.00	3131-482	40.00
1/4	90 DEG	3131-463	33.75	3131-483	33.75
1/3	60 DEG	3131-464	70.00	3131-484	70.00
1/3	75 DEG	3131-465	62.00	3131-485	62.00
1/3	90 DEG	3131-466	42.65	3131-486	42.65
1/2	60 DEG	3131-467	94.00	3131-487	94.00
1/2	75 DEG	3131-468	82.00	3131-488	82.00
1/2	90 DEG	3131-469	64.00	3131-489	64.00

## Thread Grinding Diamond Tools



For use on Jones & Lamson, Ex-Cell-O & similar thread grinding equipment.

SIZE	MACHINE	60 DEG		90 DEG	
		ORDER NO.	PRICE	ORDER NO.	PRICE
1/4 x 1	J & L	3131-605	\$9.80	3131-607	\$9.80
3/8 x 1-5/8	EX-CELL-O	3131-615	9.80	-	-

## Hand Diamond Dressers



7/16" Shank Size - 8" Overall Length

Dressers fitted with plastic handles. Ideal for dressing wheels for Surface Grinders, Universal Grinders, etc.

CARAT SIZE	ORDER NO.	PRICE
1/4	3131-451	\$6.75
1/3	3131-452	8.55
1/2	3131-453	10.75
3/4	3131-454	18.10
1	3131-455	25.65

# Diamond Tools

## Machine-Use Single Point Diamond Dressers Preferred Grade Diamond

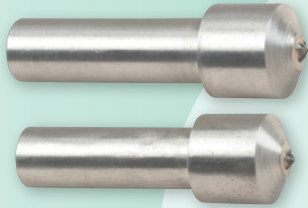

CARAT SIZE	LARGE NORTON Shank: 7/16 x 1-1/2 Head: 5/8" x 5/8"		CINCINNATI Shank: 7/16 x 2 Head: 5/8" x 5/8"	
	ORDER NO.	PRICE	ORDER NO.	PRICE
1/4	3131-391	\$18.60	3131-381	\$18.60
1/3	3131-392	22.40	3131-382	22.40
1/2	3131-393	30.00	3131-383	30.00
3/4	3131-394	44.00	3131-384	44.00
1	3131-395	60.00	3131-385	60.00
1-1/2	3131-396	95.10	3131-386	95.10

## Natural & Lapped Chisels



For use on radius dressers to form radii, steps, or contours. Tools shown are 1/4 Carat.

SHANK SIZE	NATURAL CHISEL EDGE		60° LAPPED CHISEL	
	ORDER NO.	PRICE	ORDER NO.	PRICE
3/8 x 2-1/2"	3131-520	\$30.10	3131-500	\$47.30
7/16 x 2-1/2"	3131-530	30.10	3131-510	47.30

## Multi Point Cluster Dressing Tools

5/8" Diameter Head,  
7 Diamonds

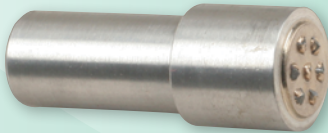

For straight face and side dressing finishes.

CARAT SIZE	3/8 SHK ORDER NO.	7/16 SHK ORDER NO.	1/2 SHK ORDER NO.	PRICE
1	3131-400	3131-415	3131-430	\$26.00
2	3131-405	3131-420	3131-435	34.00
3	3131-410	3131-425	3131-440	42.00

## Diamond Hones

Features:

- Resin Bond, 100% Concentration.
- Diamond Length: 1"
- 3/8" width square
- Overall Length: 4"



### DOUBLE END

GRIT	ORDER NO.	PRICE
100/180	3131-640	\$39.00
150/220	3131-641	39.00
180/320	3131-642	39.00
220/400	3131-643	39.00

### SINGLE END

GRIT	ORDER NO.	PRICE
100	3131-644	\$27.00
150	3131-645	27.00
220	3131-646	27.00
320	3131-647	27.00
400	3131-648	27.00
600	3131-649	27.00

## Diamond Wheel Dressers



SIZE	ORDER NO.	PRICE EACH
0	3131-670	\$7.40
1	3131-671	8.35
2	3131-672	13.05

## Cutters For Diamond Wheel Dressers



SIZE	ORDER NO.	PRICE EACH
0	3131-675	\$1.55
1	3131-676	2.35
2	3131-677	4.65

## T-Handle Diamond Dressers



Used for hand truing and dressing. A broad, flat surface of diamonds in a matrix. 3/8" x 6" Shank. 1/2" W x 1-1/2" L head. 6-1/2" OAL.

GRADE	ORDER NO.	PRICE
Medium	3131-592	\$145.80



# Diamond Wheels

2

## Straight Diamond Wheels – Type D1A1

Resin Bond, With Diamonds in Periphery  
1/8" Diamond Depth, 150 Grit

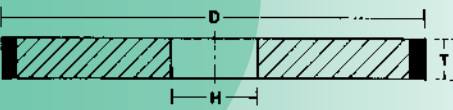

75 Concentration – Economical Grinding  
100 Concentration – For Surface Grinding, Longer life.

D DIAM.	T THICKNESS	H HOLE DIAM.	75 CONCENTRATION		100 CONCENTRATION	
			150 GRIT ORDER NO.	PRICE	150 GRIT ORDER NO.	PRICE
4	1/8	1-1/4	-	-	3130-128	\$ 78.25
4	1/4	1-1/4	-	-	3130-148	110.00
5	1/8	1-1/4	-	-	3130-228	85.35
5	1/4	1-1/4	-	-	3130-248	125.00
6	1/8	1-1/4	3130-323	\$ 86.25	3130-328	106.50
6	1/4	1-1/4	3130-343	111.10	3130-348	135.50
6	3/8	1-1/4	3130-363	150.50	3130-368	170.00
6	1/2	1-1/4	3130-383	158.25	3130-388	210.00
7	1/8	1-1/4	-	-	3130-428	138.00
7	1/4	1-1/4	3130-443	133.35	3130-448	170.00
7	3/8	1-1/4	-	-	3130-468	191.50
7	1/2	1-1/4	-	-	3130-488	232.00
8	1/4	1-1/4	-	-	3130-548	208.00
8	1/2	1-1/4	-	-	3130-588	252.00

Other Grits, Diamond Depths and Arbor Hole Diameters available.

## Diamond Cut-Off Wheels – Type D1A1R

Resin Bond, 100% Concentration, 1/4" Depth

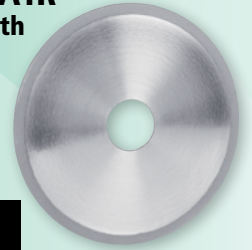
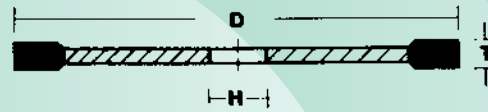

For cutting-off on Carbide.

D DIAM.	T THICKNESS	H HOLE DIAM.	GRIT	ORDER NO.	PRICE
6	.035	1-1/4	150	3130-910	\$ 84.45
6	.045	1-1/4	150	3130-915	103.10

## Diamond Face Wheels – Type D6A2C

Resin Bond, Plate Mounted, 150 Grit

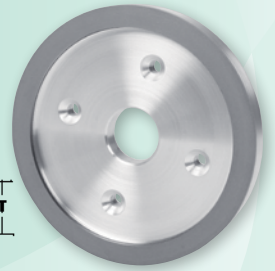
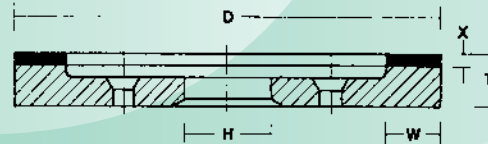

For Carbide Tool Grinders. Bolt holes countersunk for maximum safety.

D DIAM.	T THICKNESS	H HOLE DIAM.	W RIM WIDTH	X DIAMOND DEPTH	CONCN.	ORDER NO.	PRICE
6	3/4	1-1/4	1/2	1/8	75%	3130-953	\$161.00
6	3/4	1-1/4	1/2	1/8	100%	3130-958	184.00
6	3/4	1-1/4	3/4	1/16	75%	3130-963	97.80
6	3/4	1-1/4	3/4	1/16	100%	3130-968	183.00
6	1	1-1/4	3/4	1/16	75%	3130-983	131.00

## Diamond Flaring Cup Wheels – Type D11V9

Resin Bond Diamond in the periphery and on the face.  
Grind with face only.

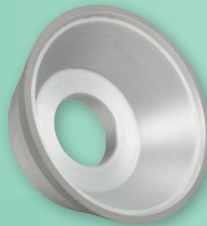
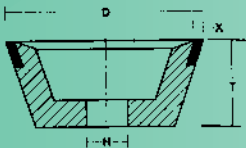

For use with Tool & Cutter Grinders.

D DIAM.	T THICKNESS	H HOLE DIAM.	X DIAMOND DEPTH	CONCN.	100 GRIT ORDER NO.	150 GRIT ORDER NO.	PRICE
3-3/4	1-1/2	1-1/4	1/8	75%	3129-121	3129-123	\$ 99.60
3-3/4	1-1/2	1-1/4	1/8	100%	3129-126	3129-128	112.00
5	1-3/4	1-1/4	1/8	75%	3129-221	3129-223	114.70
5	1-3/4	1-1/4	1/8	100%	3129-226	3129-228	126.25

## Diamond Dish Wheels – Type D12A2

Resin Bond. Diamond on the face (rim).  
100% Concentration, 150 Grit

T THICKNESS	H HOLE DIAM.	B DISH ANGLE	E BACK THICKNESS	K INSIDE FLAT	X DIAMOND DEPTH
1"	1-1/4	30	1/2	2-5/8	1/8

Used for sharpening Cutting Tools.

D DIAMETER	W RIM WIDTH	ORDER NO.	PRICE
6	3/16	3129-358	\$129.00
6	1/4	3129-368	142.00
6	3/8	3129-378	189.00



## Diamond Flaring Cup Wheels – Type D11A2

Resin Bond. Diamond on the face (rim).

100% Concentration, 150 Grit

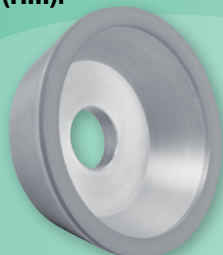
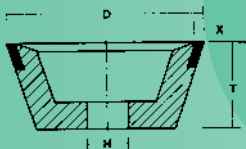

For use with Tool & Cutter Grinders.

D DIAM.	T THICKNESS	H HOLE DIAM.	W RIM WIDTH	X DIAMOND DEPTH	ORDER NO.	PRICE
3	7/8	1-1/4	3/8	1/8	3129-308	\$105.40
4	1-1/4	1-1/4	1/2	1/8	3129-318	129.00
5	1-3/4	1-1/4	3/8	1/8	3129-328	150.50

## 5 Inch Diamond Facewheels– 5" x 1/4" x 3"

Resin Bond, Steel Core, 100% Concentration

For Leonard, Cold Grind and similar type grinders.

STANDARD SECTION	120 GRIT ORDER NO.	220 GRIT ORDER NO.	320 GRIT ORDER NO.	PRICE
1/32	3129-407	3129-409	3129-412	\$172.00
1/16	3129-427	3129-429	3129-432	189.00



# Diamond Dressers

## Optical Radius Angle Dresser Visual Universal Wheel Dresser

Adaptable to surface grinders and universal tool grinders. 3X lens magnification through the spindle allows the operator to view the diamond point for radii and angle forming. Easy and accurate.

**Order No. 3131-684**  
**Price: .....\$561.50**

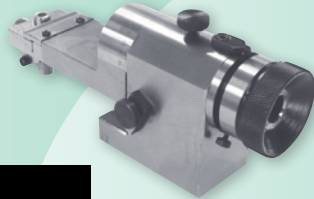

SPECIFICATIONS	
Center Height	2.5"
Max. Wheel Diameter	8"
Max. Convex Radius	1/2"
Max. Concave Radius	1"
Dressing Angle	90 - 0 - 90 (1 deg incr)
Tangential Travel	.89" either side
Mounting Surface	3.27 x 1.87"
Overall Length	8.39"
Overall Height	3.94"

- Accuracy to 0.0001"
- Gauge block setting
- Radius and angle can be done perfectly tangent
- Compact design
- Wt. 7.7 lbs.
- Complete with Diamond Dressers, Hex Keys and Wood Case.

## Precision Punch Former & Radius Wheel Dresser

For grinding wheel and punch forming applications. Concave and Convex radii. Hardened tool steel construction. Fitted case.

**Order No. 3131-686**  
**Price: .....\$1025.60**

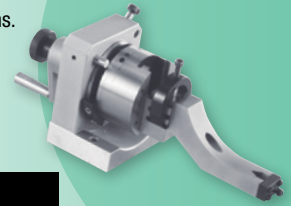

SPECIFICATIONS	
Max. Dia. - Workpiece	1-1/4"
V-Block	1-3/16"
Adjusting System	Rack and Pinion
Center Height	3-1/2"
Indexing Divisions	24 every 15 Degree +/-10 seconds
Angle Setting	By sine system
Roundness	0.0001"
Parallelism	w/i 0.0001" in 4"
Squareness	w/i 0.0002" in 4"
Graduation	360 Deg.
Weight	17.0 lbs.

## Radius and Angle Dresser

For use on all OD, ID and surface grinding applications.

No height gage or set-up aids required. Radius is set on the grinder by measuring over the two pins or by inserting a gage block, for direct reading. Inside or outside radius is determined by using either the left hand or right hand pins. Uses 3/8" shank diamond tool.

**Order No. 3131-687** Price: ..\$525.60

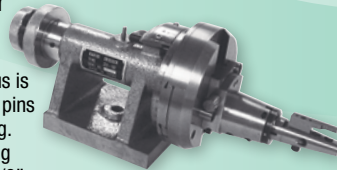

SPECIFICATIONS			
Max. Wheel Diameter	12"	Center Line Of Tool	3.4"
Max. Convex Radii	0 to 1-5/8"	Overall Length	16-5/8"
Max. Concave Radii	0 to 4"	Weight	30 lbs.
Tangent Travel	2"	Accuracy	.0005"

## Profile Wheel Dresser

Accurate and versatile Radius and Angle Wheel Dresser.

\*Fast and easy set-ups without elaborate accessories. Only a micrometer and hex key wrench are needed.

\*Dress 2 angles tangent to a radius in one continuous motion to within .0001".

\*Precise and sharp contours, concave and convex, are consistently obtained at a full 180 Degree range.

**Order No. 3131-685**  
**Price: .....\$666.60**

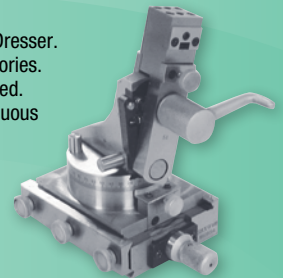

SPECIFICATIONS	
Max. Dia. - Workpiece	8"
Convex Radii	0 to 1-1/2"
Concave Radii	.030 to 1-1/2"
Center Height	3-1/2"
Height to center of diamond	6-1/2"
Dia. of Setting Pins	10mm
Overall Height	7"
Base	4-3/4 x 3-1/2 x 1-1/4"

## Diamond Nib Holder

Use on surface grinders. Holds Diamond Dresser at 15 Deg. angle.

Base dimension: 2-1/2" x 6"

Keyway: 1/2" x 7/8"

Includes 7/16 x 2" 1/4 Carat dresser.

**Order No. 3131-683 ...Price: \$21.45**

**Replacement Diamond Dresser**

**Order No. 3131-080 ...Price:\$4.55**



## Low-Boy Angle Dresser

Use on all grinding machines. Base Angle-Plate heavy, precision ground, square on six sides to .0005" accuracy. Side block pivots on hardened screws. Includes 3/8 x 2 1/4 Carat dresser.

**Order No. 3131-682**  
**Price: .....\$76.75**

**Replacement Diamond Dresser-**  
**Order No. 3131-040**  
**Price: .....\$4.55**

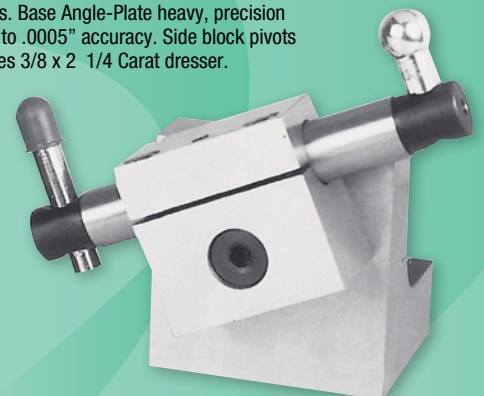

## Hi-Low Adjustable Dresser

Use on all grinding machines.

Dress O.D. and face of wheels.

Adjustable to 7" Height.

Includes 3/8 x 3" 1/4 Ct. dresser.

**Order No. 3131-681**  
**Price: .....\$46.00**

**Replacement Diamond Dresser**

**Order No. 3131-045**

**Price: .....\$4.55**

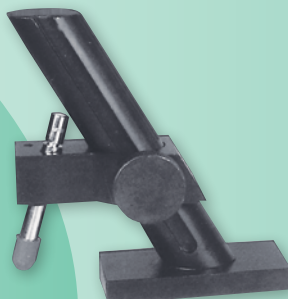

# Diamond & CBN Electro-Plated Mandrels/Jig Grinding Pins

2

Coarse Grit 80/120

Tolerance on Hardened Steel Shanks:  $+.0000/-0.0006$

Diamond plated mandrels are used for internal grinding of glass, ceramics, cemented carbides, and other hard and abrasive materials.

CBN is ideal for High Speed Steels, such as M2, M3, M7 & T16; Die Steels, such as D2, D3, HB & A&O; Alloy Steels (harder than 50Rc); Nickel and Cobalt Base Super Alloys; Titanium, and Stainless Steels.

## STYLE I

A HEAD	B HEAD LENGTH	C NECK LENGTH	D SHANK SIZE	DIAMOND ORDER NO.	CBN ORDER NO.	PRICE
.020	1/16	1/8	1/8	3128-600	3126-600	\$11.00
.025	3/32	1/4	1/8	3128-601	3126-601	9.40
.030	3/32	1/4	1/8	3128-602	3126-602	9.40
.035	3/32	1/4	1/8	3128-603	3126-603	9.40
.040	1/8	3/8	1/8	3128-604	3126-604	9.40
.045	1/8	3/8	1/8	3128-605	3126-605	9.80
.050	1/8	3/8	1/8	3128-606	3126-606	9.80
.050	1/8	1	1/8	3128-607	3126-607	11.80
.055	1/8	3/8	1/8	3128-608	3126-608	9.90
.060	1/8	3/8	1/8	3128-609	3126-609	9.70
.060	1/8	1	1/8	3128-610	3126-610	11.70
.070	5/32	1/2	1/8	3128-611	3126-611	10.30
.070	5/32	1	1/8	3128-612	3126-612	11.80
.080	5/32	1/2	1/8	3128-613	3126-613	10.90
.080	5/32	1	1/8	3128-614	3126-614	12.00
.090	5/32	1/2	1/8	3128-615	3126-615	11.00
.090	5/32	1	1/8	3128-616	3126-616	12.10
.100	5/32	1/2	1/8	3128-617	3126-617	11.00
.100	5/32	1	1/8	3128-618	3126-618	12.30
.110	5/32	1/2	1/8	3128-619	3126-619	11.30
.110	5/32	1	1/8	3128-620	3126-620	12.30
.125	5/32	1/2	1/8	3128-621	3126-621	11.90
.125	5/32	1	1/8	3128-622	3126-622	13.00
.141	1/4	1	1/4	3128-623	3126-623	16.80
.156	1/4	1	1/4	3128-624	3126-624	19.40
.188	1/4	1	1/4	3128-625	3126-625	19.40
.218	1/4	1	1/4	3128-626	3126-626	19.40
.250	1/8	1	1/4	3128-627	3126-627	19.40
.250	1/4	1	1/4	3128-628	3126-628	19.40

## STYLE I

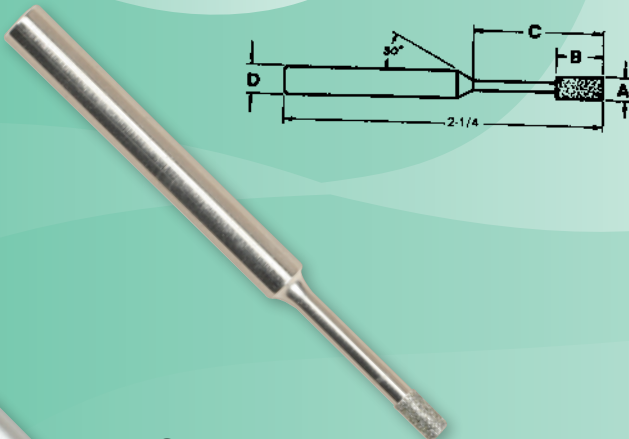

## STYLE II

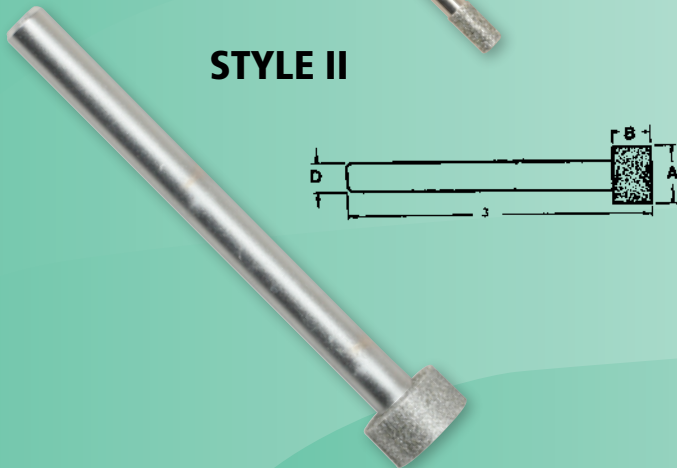

## STYLE II

A HEAD	B HEAD LENGTH	D SHANK SIZE	DIAMOND ORDER NO.	CBN ORDER NO.	PRICE
.312	1/8	1/4	3128-640	3126-640	\$24.30
.312	1/4	1/4	3128-641	3126-641	27.90
.375	1/8	1/4	3128-642	3126-642	24.30
.375	1/4	1/4	3128-643	3126-643	27.90
.500	1/4	1/4	3128-644	3126-644	33.40
.500	3/8	1/4	3128-645	3126-645	33.40
.750	1/4	1/4	3128-646	3126-646	47.40
.750	1/2	1/4	3128-647	3126-647	47.40

# Diamond Polishing & Lapping Compounds

“Universal Carrier”—

Oil or Water Soluble Stocked in 5 Gram Disposable Plastic Syringes

2

FINISH	COLOR	MICRON GRADE	MICRON RANGE	LIGHT CONCENTRATION		MEDIUM CONCENTRATION		HEAVY DUTY CONCENTRATION	
				ORDER NO.	PRICE	ORDER NO.	PRICE	ORDER NO.	PRICE
Super Fine	Yellow	3	1-5	3126-570	\$10.20	3126-571	\$12.90	3126-572	\$16.00
	Orange	5	4-8	3126-573	10.80	3126-574	15.00	3126-575	20.40
	Green	9	6-12	3126-576	11.80	3126-577	16.10	3126-578	21.40
Fine	Blue	15	10-22	3126-590	11.80	3126-591	16.10	3126-592	21.40
	Red	30	20-40	3126-593	11.80	3126-594	16.10	3126-595	21.40
	Brown	45	30-60	3126-596	11.80	3126-597	16.10	3126-598	21.40



# T1 Cut-Off Wheels – Right Angle Grinder, Die Grinders

**FLEXOVIT®**

## Razorblade® Type 1 Thin Cutoff Wheels

Razorblade® Type 1 Thin Cutoff Wheels for angle grinders are an indispensable tool for the metalworker in both production and maintenance applications.

Buy Std. Ctn. Deduct 10%



**CGW**  
CAMEL GRINDING WHEELS

## Type 1 Quickie Cut™ Right Angle Grinder Reinforced Cut-Off Wheels

Buy Std. Ctn. Deduct 10%



CGW Quickie Cut™ Reinforced Type 1 Cut-Off wheels are safe for use on Right Angle Grinders, providing excellent results on stainless steel, alloys, and ferrous. Select from B-Flex or Rigid configurations.

SIZE DIA. x THICK. x ARBOR	RPM	STD. CTN.	GRADE	ORDER NO.	PRICE EACH
4-1/2 x .045 x 7/8	13300	25	A60SST	3893-670	\$ 3.96
5 x .045 x 7/8	12000	25	A60SST	3893-675	5.06

ZA60-TB-FLEX WHEELS					
SIZE DIA. x THICK. x ARBOR	SPEC	RPM	STD. CTN.	ORDER NO.	PRICE EACH
4 1/2 x .035 x 7/8	ZA60-TB-FLEX	13,300	25	3898-653	\$1.62
5 x .040 x 7/8	ZA60-TB-FLEX	12,250	25	3898-656	1.98
6 x .040 x 7/8	ZA60-TB-FLEX	10,200	25	3898-668	2.10
7 x 1/16 x 7/8	ZA60-TB-FLEX	8,500	25	3898-671	3.36

## Weiler® Type 1 Right Angle Grinder Cutting Wheels For Steel/Metal



**WOLVERINE®**  
Aluminum Oxide / Fast Cutting



**TIGER®**  
Premium Aluminum Oxide / Long Life

Buy Std. Ctn. Deduct 10%

ZA36T RIGID WHEELS					
SIZE DIA. x THICK. x ARBOR	SPEC	RPM	STD. CTN.	ORDER NO.	PRICE EACH
4 1/2 x .045 x 7/8	ZA36-T-BF	13,300	25	3890-471	1.64
5 x .045 x 7/8	ZA36-T-BF	12,250	25	3890-472	2.01
6 x .045 x 7/8	ZA36-T-BF	10,200	25	3890-473	2.08
7 x 1/16 x 7/8	ZA36-T-BF	8,500	25	3890-474	3.22

## Mounting Mandrels

For small diameter Type 1 Wheels

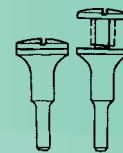

ARBOR SIZE	WHEEL THICKNESS	ORDER NO.	PRICE EACH
1/4"	.035 to 1/4	6556-489	\$9.52
3/8"	.035 to 1/4	6556-490	9.52
1/4", 3/8"	.035 to 1/4	6556-491	16.37

WOLVERINE™		TIGER™						
SIZE DIA. x THK. x AR.	MAX RPM	CASE QTY.	GRADE	ORDER NO.	PRICE EACH	GRADE	ORDER NO.	PRICE EACH
4-1/2 x .045 x 7/8	13300	25	A60T	6556-281	\$1.54	A60T	6557-020	\$2.29
4-1/2 x 1/16 x 7/8	13300	25	A60T	6556-103	1.82	A36T	6557-061	1.63
5 x .045 x 7/8	12200	25	-	-	-	A60T	6557-021	2.63
5 x 1/16 x 7/8	12200	25	A36T	6556-118	2.05	-	-	-
6 x .040 x 7/8	10200	25	A60T	6556-282	2.13	-	-	-
6 x .045 x 7/8	10200	25	A60T	6556-273	2.13	A60T	6557-022	2.78
7 x .045 x 7/8	8500	25	A60T	6556-275	2.81	-	-	-
7 x .060 x 7/8	8500	25	-	-	-	A60T	6557-023	3.27

## Small Diameter - Portable/Die Grinder -

### Fiberglass Reinforced - Aluminum Oxide - Resin Bonded

For use on air or electric straight shaft high speed right angle and die grinders. Designed for fast, burr free cutting and notching. Works especially well on thin walled tube and pipe.



Buy Std. Ctn. Deduct 10%

Use on Straight & Die Grinders

CGW				Weiler WOLVERINE™				FLEXOVIT USA					
SIZE DIA. x THICK. x ARBOR	MAX. RPM	GRADE	STD. CTN.	ORDER NO.	PRICE EACH	GRADE	STD. CTN.	ORDER NO.	PRICE EACH	GRADE	STD. CTN.	ORDER NO.	PRICE EACH
3 x .035 x 1/4	24000	A60	50	3890-410*	\$1.22	A60T	100	6556-061	\$1.15	A60T	100	3893-610	\$3.06
3 x .035 x 3/8	24000	A60	50	3890-415*	1.22	A60T	100	6556-062	1.15	A60T	100	3893-615	3.06
3 x 1/16 x 1/4	24000	A36	50	3890-420	1.24	A36T	100	6556-065	1.24	A46T	50	3893-620	3.06
3 x 1/16 x 3/8	24000	A36	50	3890-425	1.24	A36T	100	6556-068	1.24	A46T	50	3893-625	3.06
3 x 1/8 x 1/4	24000	A24	25	3890-430	1.40	A36T	100	6556-270	1.35	A36R	25	3893-630	4.32
3 x 1/8 x 3/8	24000	A24	25	3890-435	1.40	A36T	100	6556-076	1.35	A36R	25	3893-635	4.32
4 x .035 x 1/4	19000	A60	50	3890-440*	1.59	A60T	50	6556-165	1.49	A60T	100	3893-640	4.45
4 x .035 x 3/8	19000	A60	50	3890-445*	1.59	A60T	25	6556-080	1.49	A60T	100	3893-645	4.45
4 x 1/16 x 1/4	19000	A36	50	3890-450	1.73	A36T	50	6556-166	1.55	A46T	50	3893-650	4.45
4 x 1/16 x 3/8	19000	A36	50	3890-455	1.73	A36T	25	6556-086	1.55	A46T	50	3893-655	4.45
4 x 1/8 x 1/4	19000	A24	25	3890-460	1.96	A36S	50	6556-167	1.93	A36R	25	3893-660	2.99
4 x 1/8 x 3/8	19000	A24	25	3890-465	1.94	A36T	25	6556-099	1.93	A36R	25	3893-665	5.17

\* 1/32" Thick, \*\* 1/16" Thick

# Type 1 Cut-Off Wheels

## Circular Saw Wheels Fiberglass Reinforced – Resin Bonded

Designed to meet the demands of the professional contractor.  
A general purpose wheel providing fast cutting action.



**Buy  
Std. Ctn.  
Deduct  
10%**

			CGW			CGW			FLEXOVIT USA			FLEXOVIT USA		
			METAL, STAINLESS			MASONRY, CONCRETE			METAL, STAINLESS			MASONRY, CONCRETE		
SIZE DIA. x THICK. x ARBOR	MAX. RPM	GRADE	ORDER NO.	PRICE EACH	GRADE	ORDER NO.	PRICE EACH	GRADE	ORDER NO.	PRICE EACH	GRADE	ORDER NO.	PRICE EACH	
7 x 3/32 x 5/8	8600	A24R	3890-475	\$1.53	C24R	3890-477	\$1.44	A36TB38	3893-700	\$6.80	-	-	-	
7 x 1/8 x 5/8	8600	-	-	-	-	-	-	-	-	-	C30UB64	3893-710	\$7.29	
8 x 3/32 x 5/8	7500	-	-	-	-	-	-	A36TB38	3893-705	7.63	-	-	-	
8 x 1/8 x 5/8	7500	-	-	-	-	-	-	-	-	-	C30UB64	3893-715	8.21	

CGW –  
Std. Ctns. of 25  
  
Flexovit USA –  
Std. Ctns. of 25

## Chopsaw/Mitre Saw Wheels Fiberglass Reinforced – Resin Bonded

Used on lower horsepower bench top chopsaws and mitre saws,  
these wheels combine optimum cutting speed and wheel life.

			CGW			FLEXOVIT USA			
SIZE DIA. x THICK. x ARBOR	MAX. RPM	GRADE	STD. CTN.	ORDER NO.	PRICE EACH	GRADE	STD. CTN.	ORDER NO.	PRICE EACH
10 x 3/32 x 5/8	6130	A24R	10	3890-485	\$2.72	-	-	-	-
12 x 3/32 x 1	5100	A36P	10	3890-510	7.74	A30RB	10	3893-730	\$10.17
14 x 3/32 x 1	4400	A36P	10	3890-515	8.43	A30RB	10	3893-735	13.88



## High Speed Gas & Electric Saw Wheels Fiberglass Reinforced – Resin Bonded

Durable, hard working wheels for a variety of job site applications.



			CGW			CGW			FLEXOVIT USA			FLEXOVIT USA		
			METAL, STAINLESS			MASONRY, CONCRETE			METAL, STAINLESS			MASONRY, CONCRETE		
SIZE DIA. x THICK. x ARBOR	MAX. RPM	GRADE	ORDER NO.	PRICE EACH	GRADE	ORDER NO.	PRICE EACH	GRADE	ORDER NO.	PRICE EACH	GRADE	ORDER NO.	PRICE EACH	
12 x 1/8 x 1	6300	-	-	-	-	-	-	A24/305B	3893-800	\$9.86	C30UB	3893-820	\$9.86	
12 x 1/8 x 20MM	6300	-	-	-	-	-	-	A24/305B	3893-805	9.86	C30UB	3893-825	9.86	
12 x 5/32 x 1	6300	A24R	3890-520	\$8.28	C24R	3890-530	\$3.75	-	-	-	-	-	-	
12 x 5/32 x 20MM	6300	A24R	3890-522	8.28	C24R	3890-532	3.75	-	-	-	-	-	-	
14 x 1/8 x 1	5200	-	-	-	-	-	-	A24/305B	3893-810	16.25	C30UB	3893-830	16.25	
14 x 1/8 x 20MM	5200	-	-	-	-	-	-	A24/305B	3893-815	16.25	C30UB	3893-840	16.25	
14 x 5/32 x 1	5200	A24R	3890-524	11.94	C24R	3890-534	4.88	-	-	-	-	-	-	
14 x 5/32 x 20MM	5200	A24R	3890-526	11.94	C24R	3890-536	4.88	-	-	-	-	-	-	

CGW –  
Std. Ctns. of 10  
  
Flexovit USA –  
Std. Ctns. of 10

## Type 1 Stationary Saw Wheels Fiberglass Reinforced – Resin Bonded

For use in production cut-off applications. Fast cutting, reliable performance.

			CGW			FLEXOVIT USA			
SIZE DIA. x THICK. x ARBOR	MAX. RPM	GRADE	STD. CTN.	ORDER NO.	PRICE EACH	GRADE	STD. CTN.	ORDER NO.	PRICE EACH
10 x 1/8 x 5/8	6130	A24R	10	3890-487	\$2.85	A30RB	10	3893-750	\$ 10.69
10 x 1/8 x 1	6130	-	-	-	-	A30RB	10	3893-755	13.63
12 x 1/8 x 1	5100	A24R	10	3890-490	5.10	A30RB	10	3893-760	17.05
14 x 1/8 x 1	4300	A24R	10	3890-495	9.43	A30RB	10	3893-765	24.70
16 x 5/32 x 1	3820	A24R	10	3890-500	21.54	A30RB	10	3893-770	34.99
20 x 5/32 x 1	3050	A24R	10	3890-505	22.79	-	-	-	-
20 x 3/16 x 1	3066	-	-	-	-	A30RB	10	3893-775	62.84



# Type 27 Depressed Center Grinding Wheels



## Type 27 Grinding Wheels

### Fiberglass Reinforced – Resin Bonded For Metal, Stainless

For safe and efficient metal removal in all portable grinding operations. Remove weld beads, burrs, and rough edges aggressively, yet economically. Long life.

**A24N Fast Cut:** Aluminum Oxide Grain. Soft N-grade bond for fast stock removal.

Excellent ratio of stock removal/wheel loss.

**A24R Fast Cut:** Aluminum Oxide Grain. R-grade bond for excellent life and stock removal.

**ZA24T:** Zirconia Aluminum Oxide Grain.

High performance design for fast cutting and longer life. Excellent cutting of ferrous metals and stainless steel.



**Buy  
Std. Ctn.  
Deduct  
10%**

1

SIZE			MAX. RPM	ALUMINUM OXIDE				ULTRA PREMIUM ZIRCONIA			
DIA. x THICK. x ARBOR	GRADE	STD. CTN.		ORDER NO.	PRICE EACH	GRADE	STD. CTN.	ORDER NO.	PRICE EACH		
4 x 1/4 x 5/8	A24N	25	3890-035	\$1.66	-	-	-	-			
4-1/2 x 1/8 x 7/8	A24R	25	3890-040	1.10	-	-	-	-			
4-1/2 x 1/4 x 7/8	A24R	25	3890-045	1.74	ZA24T	25	3890-845	\$4.17			
4-1/2 x 1/4 x 5/8-11	A24R	10	3890-050	3.40	ZA24T	10	3890-850	6.07			
5 x 1/4 x 7/8	A24N	25	3890-060	2.27	-	-	-	-			
7 x 1/4 x 5/8-11	A24R	10	3890-075	5.37	ZA24T	10	3890-875	9.48			
9 x 1/4 x 5/8-11	A24N	10	3890-095	8.80	-	-	-	-			

## FLEXOVIT

### High Performance Type 27 Wheels

The hardest working aluminum oxide wheels available. Precision made to ensure smooth and safe operation, sets the standards for fast material removal, rugged reliability and long life. Made in USA



**Buy  
Std. Ctn.  
Deduct  
10%**

1

SIZE			MAX. RPM	ALUMINUM OXIDE		
DIA. x THICK. x ARBOR	GRADE	STD. CTN.		ORDER NO.	PRICE EACH	
4-1/2 x 1/4 x 7/8	A30S	25	3890-645	\$3.62		
4-1/2 x 1/4 x 5/8-11	A30S	10	3890-650	5.24		
5 x 1/4 x 7/8	A30S	25	3890-660	6.05		
7 x 1/4 x 7/8	A30S	10	3890-670	7.65		
7 x 1/4 x 5/8-11	A30S	10	3890-675	9.54		
9 x 1/4 x 7/8	A30S	10	3890-690	11.18		



### Type 27 Grinding Wheels For Steel/Metal

Fast Grinding and consistent performance at a good value for everyday, general purpose use.

**A24R:** Aluminum Oxide Grain. Fast grinding on metal.



**Buy  
Std. Ctn.  
Deduct  
10%**

1

SIZE			MAX. RPM	STD. CTN.	WOLVERINE™ ALUMINUM OXIDE		PRICE EACH
DIA. x THICK. x ARBOR	GRADE	ORDER NO.					
4 x 1/4 x 5/8	A24R	6556-473	\$1.99				
4-1/2 x 1/4 x 7/8	A24R	6556-464	1.78				
4-1/2 x 1/4 x 5/8-11	A24R	6556-454	3.28				
7 x 1/4 x 5/8-11	A24R	6556-468	6.27				

# Type 27 Depressed Center Cutting/Combo Wheels



## Type 27 Cut/Grind/Finish Reinforced Rt. Angle Grinder Wheels

High performance wheels made to cut quickly, grind easily and finish work surfaces with ONE wheel. Fiberglass net reinforcement provides added strength and flexibility.

For working on flat grinding surfaces. Most efficient when used between 0° - 15° angle. The best choice for smooth finishing. Suitable For: Steel & Stainless Steel. Contaminate free wheel has < 0.1% iron, sulfur, or chlorine for rust-free and corrosion-free results.



**Buy  
Std. Ctn.  
Deduct  
10%**

1

SIZE DIA. x THICK. x ARBOR	SPEC	MAX. RPM	STD. CTN.	ORDER NO.	PRICE EACH
4 1/2 x 3/32 x 7/8	A36S	13,300	25	3898-755	\$1.96
4 1/2 x 3/32 x 5/8-11	A36S	13,300	10	3898-756	3.84
5 x 3/32 x 7/8	A36S	12,250	25	3898-760	2.42
5 x 3/32 x 5/8-11	A36S	12,250	10	3898-761	4.30
6 x 3/32 x 7/8	A36S	10,200	25	3898-765	3.50
6 x 3/32 x 5/8-11	A36S	10,200	10	3898-766	5.38



## Type 27 Quickie Cut™ Thin Reinforced Right Angle Grinder Cut-Off Wheels

CGW Quickie Cut™ Thin Reinforced Type 27 Cut-Off wheels are an excellent general purpose wheel with an Aluminum Oxide / Zirconia mixture. Zirconia grain allows for faster cutting and longer life. Use on Steel and Stainless Steel.



**Buy  
Std. Ctn.  
Deduct  
10%**

1

SIZE DIA. x THICK. x ARBOR	SPEC	MAX. RPM	STD. CTN.	ORDER NO.	PRICE EACH
4 x .045 x 5/8	ZA60-S-BF	15,300	25	3898-705	\$1.80
4 1/2 x .045 x 7/8	ZA60-S-BF	13,300	25	3898-710	1.76
5 x .045 x 7/8	ZA60-S-BF	12,250	25	3898-715	2.07
6 x .045 x 7/8	ZA60-S-BF	10,200	25	3898-720	2.31

# Abrasive Flap Discs

Zirconium Abrasive Flap Discs are used for coarse and intermediate grinding of welds, deburring, rust removal and snagging. Bridges the gap between angle grinding wheels and resin fiber discs, providing aggressive cutting action and longer life than fiber discs.

**Buy Std. Ctn. Deduct 10%**

## Type 29 – Angled Style Flap Discs – Zirconium Grain

A working angle of 15 to 25 Degrees. Excellent for contour or edge work.

- Phenolic resin/fiber backing is used to prevent scratching the work piece during operation.
- Aluminum backing provides rigid support for maximum aggression; recyclable.
- CGW XL discs have approximately 60% more material.

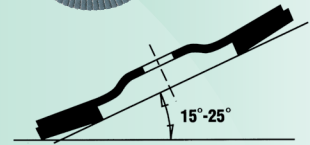
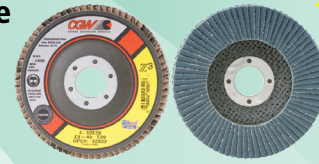

		WOLVERINE™		CGW		CGW XL		Weiler TIGER				
SIZE	GRIT	STD. CTN.	PHENOLIC BACKING		PHENOLIC BACKING		PHENOLIC BACKING		PHENOLIC BACKING		ALUMINUM BACKING	
			ORDER NO.	PRICE	ORDER NO.	PRICE	ORDER NO.	PRICE	ORDER NO.	PRICE	ORDER NO.	PRICE
4-1/2 x 7/8	24	10	-	-	5720-422	\$4.85	-	-	6550-601	\$7.83	6550-511	\$8.68
4-1/2 x 7/8	36	10	6531-343	\$3.74	5720-423	4.66	5720-823	\$5.86	6550-602†	3.25	6550-512	8.68
4-1/2 x 7/8	40	10	6531-344	3.74	5720-424	4.66	5720-824	5.86	6550-603†	3.25	6550-513	8.68
4-1/2 x 7/8	60	10	6531-345	3.74	5720-426	4.66	5720-826	5.86	-	-	6550-514	8.68
4-1/2 x 7/8	80	10	6531-346	3.74	5720-428	4.66	5720-828	5.86	6550-605†	POA	6550-515	8.68
4-1/2 x 7/8	120	10	6531-347	3.74	5720-432	4.66	5720-832	5.86	6550-606	7.83	6550-516	8.68
7 x 7/8	40	10	-	-	5720-484	9.69	-	-	-	-	6550-533	17.36
7 x 7/8	60	10	-	-	5720-486	9.69	-	-	-	-	6550-534	17.36
7 x 7/8	80	10	-	-	5720-488	9.69	-	-	-	-	6550-535	POA

Other sizes, and 5/8-11 Hub Style are also available. Std. Carton Qty. only.

† Limited Quantities

## Type 27 – Flat Style Flap Discs

Ideal for working angles less than 15 Degrees. Smooth grinding.

### Zirconium Grain

High rate of stock removal and long life in demanding applications.

**CGW XL and Weiler Big Cat®** Abrasive Flap Discs feature a thicker disc with a higher density of flaps which conform to curved surfaces producing a consistent finish. 30% to 40% longer life than standard flap discs. For those who value parts-per-disc over price-per-disc.

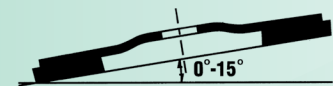

		CGW		Weiler TIGER		CGW XL		Weiler TIGER Big Cat®		
SIZE	GRIT	STD. CTN.	PHENOLIC BACKING ZIRCONIUM GRAIN		PHENOLIC BACKING ZIRCONIUM GRAIN		PHENOLIC BACKING ZIRCONIUM GRAIN		PHENOLIC BACKING ZIRCONIUM GRAIN	
			ORDER NO.	PRICE	ORDER NO.	PRICE	ORDER NO.	PRICE	ORDER NO.	PRICE
4-1/2 x 7/8	24	10	5720-222	\$4.85	-	-	-	-	-	-
4-1/2 x 7/8	36	10	5720-223	4.66	-	-	5720-623	\$5.86	-	-
4-1/2 x 7/8	40	10	5720-224	4.66	6550-703†	POA	5720-624	5.86	6550-803	\$9.23
4-1/2 x 7/8	60	10	5720-226	4.66	6550-704†	\$3.25	5720-626	5.86	6550-804	9.23
4-1/2 x 7/8	80	10	5720-228	4.66	6550-705†	3.25	5720-628	5.86	6550-805	9.23
4-1/2 x 7/8	120	10	5720-232	4.66	6550-706	7.83	5720-632	5.86	6550-806	9.23
7 x 7/8	40	10	5720-284	9.69	-	-	-	-	-	-
7 x 7/8	60	10	5720-286	9.69	-	-	-	-	-	-
7 x 7/8	80	10	5720-288	9.69	-	-	-	-	-	-

† Limited Quantities

## Adapting Nuts & Spanner Wrench

- For discs with 7/8" arbor hole

DESCRIPTION	THREAD	ORDER NO.	PRICE EACH
Adapting nuts	5/8-11	6556-494	\$31.32
Spanner wrench	-	6556-495	25.21

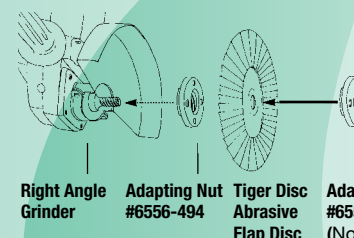
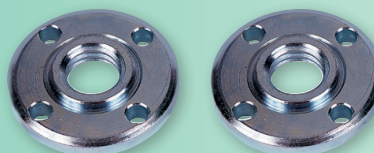

Right Angle Grinder Adapting Nut #6556-494 Tiger Disc Abrasive Flap Disc Adapting Nut #6556-494 (Not for use with Resin Fiber Discs)



# Mini Flap Discs & Quick Change Discs

## Mini Flap Discs - Type 27 Zirconia Grain



For use on Die Grinders, these mini flap discs combine grinding and finishing applications into one step, while providing the convenience and versatility of Quick Change Discs. They are designed to prevent walking, allow access to tight areas, and reduce heat build-up.

### Applications:

- Grinding and finishing in one step.
- Grinding, deburring and blending on steel/stainless steel.
- Jobs requiring high aggression & rapid stock removal.
- Metal fabrication requiring light weld blending or edge chamfering.

USA MADE							
SIZE	GRIT	RPM	PKG. QTY.	TYPE 27 (R HUB)		TYPE 27 (S HUB)	
				ORDER NO.	PRICE PER PACK	ORDER NO.	PRICE PER PACK
2"	36	24,000	10	5722-023	\$31.51	6550-932	\$41.88
2"	40	24,000	10	5722-024	31.51	6550-933	41.88
2"	60	24,000	10	5722-026	31.51	6550-934	41.88
2"	80	24,000	10	5722-028	31.51	6550-935	41.88
2"	120	24,000	10	5722-030	31.51	6550-936	41.88
3"	36	20,000	10	5722-033	47.75	6550-912	54.10
3"	40	20,000	10	5722-034	47.75	6550-913	54.10
3"	60	20,000	10	5722-036	39.53	6550-914	54.10
3"	80	20,000	10	5722-038	39.53	6550-915	54.10
3"	120	20,000	10	5722-040	39.53	6550-916	54.10



## Quick Change Laminated Discs

Use on Die Grinders for deburring, blending, finishing, removing tool marks, and die polishing on all types of materials. Suitable for a wide variety of light fabrication, repair and maintenance applications. Strong 2-Ply design for flat or contour work.

- Aluminum Oxide - Color: Brown** General purpose disc for grinding, deburring, and blending on ferrous metals.
- Zirconia AO w/Grinding Aid - Color: Green** Excellent disc for rapid stock removal on Stainless Steel. Lubricated super-size Grinding Aid coat for cooler running.
- Premium Ceramic - Color: Pink** Premium grain for greater durability and aggressive cut rates, including hard metals.

Turn On style, (S-Hub) shown

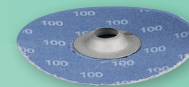

DIAM.	GRIT	RPM	PKG. QTY.	ALUMINUM OXIDE			ZIRCONIA AO W/GRINDING AID			PREMIUM CERAMIC		
				ROLL ON (R HUB) ORDER NO.	TURN ON (S HUB) ORDER NO.	PRICE PER PACK	ROLL ON (R HUB) ORDER NO.	TURN ON (S HUB) ORDER NO.	PRICE PER PACK	ROLL ON (R HUB) ORDER NO.	TURN ON (S HUB) ORDER NO.	PRICE PER PACK
2"	36	25,000	50	5722-223	5722-623	\$30.45	5722-323	5722-723	\$44.27	5722-523	5722-923	\$48.85
	40	25,000	50	5722-224	5722-624	28.42	5722-324	5722-724	39.19	5722-524	5722-924	46.04
	50	25,000	50	5722-225	5722-625	28.54	5722-325	-	39.19	5722-525	5722-925	44.27
	60	25,000	50	5722-226	5722-626	28.54	5722-326	5722-726	39.19	5722-526	5722-926	39.19
	80	25,000	50	5722-228	5722-628	27.53	5722-328	5722-728	39.19	5722-528	5722-928	37.42
	100	25,000	50	5722-230	5722-630	27.53	-	-	-	5722-530	5722-930	36.29
	120	25,000	50	5722-232	5722-632	27.53	5722-332	5722-732	39.19	5722-532	5722-932	36.29
3"	36	20,000	25	5722-243	5722-643	24.49	5722-343	-	32.41	5722-543	5722-943	45.73
	40	20,000	25	5722-244	5722-644	22.44	5722-344	-	28.54	5722-544	5722-944	42.24
	50	20,000	25	5722-245	5722-645	22.51	5722-345	-	28.54	5722-545	5722-945	39.83
	60	20,000	25	5722-246	-	22.51	5722-346	-	27.46	5722-546	5722-946	34.89
	80	20,000	25	5722-248	5722-648	21.19	5722-348	-	27.46	5722-548	5722-948	32.41
	100	20,000	25	5722-250	5722-650	21.19	-	-	-	5722-550	5722-950	32.03
	120	20,000	25	5722-252	-	21.19	5722-352	-	27.46	5722-552	5722-952	32.03



## Quick Change Disc Rubber Holder Pads

- Medium grade reinforced rubber holder pad.
- Available for either internally threaded (S Hub) or externally threaded (R Hub) Quick Change discs.



SIZE	RPM	R-HUB		S-HUB	
		ORDER NO.	PRICE EACH	ORDER NO.	PRICE EACH
1-1/2"	25,000	5723-401	\$6.96	5723-411	\$7.73
2"	25,000	5723-402	8.60	5723-412	8.12
3"	20,000	5723-403	8.57	5723-413	9.45

# Resin Fibre Discs

1

**Buy  
Std. Ctn.  
Deduct  
10%**

GRAIN SELECTOR		
GRAIN	FEATURES	APPLICATIONS
<b>Aluminum Oxide</b>	<ul style="list-style-type: none"> <li>• Fast, smooth cutting action</li> <li>• Tough and flexible</li> <li>• High resistance to heat, glazing, and loading</li> </ul>	<ul style="list-style-type: none"> <li>• All purpose weld removal and blending</li> <li>• Surface preparation and finishing of ferrous metals, plastic, and wood</li> </ul>
<b>Zirconium</b>	<ul style="list-style-type: none"> <li>• Superior cutting action</li> <li>• More durable – longer life</li> <li>• Ultra high resistance to heat, glazing, and loading</li> </ul>	<ul style="list-style-type: none"> <li>• High performance grinding of stainless steel, tool steel, and hard-to-grind materials and exotic metals.</li> </ul>



		CGW		WOLVERINE™				3M™ †			
		ALUMINUM OXIDE		ZIRCONIUM		ALUMINUM OXIDE		ALUMINUM OXIDE			
SIZE	GRIT	STD. CTN.	ORDER NO.	PRICE	ORDER NO.	PRICE	ORDER NO.	PRICE	ORDER NO.	PRICE	
4 x 5/8	24	25	5710-152	\$0.60	-	-	-	-	-	-	-
4 x 5/8	80	25	5710-158	0.52	-	-	-	-	-	-	-
4-1/2 x 7/8	16	25	5710-201	0.76	-	-	-	-	-	-	-
4-1/2 x 7/8	24	25	5710-202	0.63	5710-432	\$0.93	6559-571	\$0.82	5616-132	\$2.22	-
4-1/2 x 7/8	36	25	5710-203	0.60	5710-433	0.87	6559-573	0.76	-	-	-
4-1/2 x 7/8	50	25	5710-205	0.58	5710-435	0.81	6559-575	0.74	-	-	-
4-1/2 x 7/8	60	25	5710-206	0.56	5710-436	0.76	6559-576	0.72	5616-136	1.95	-
4-1/2 x 7/8	80	25	5710-208	0.51	5710-438	0.72	6559-577	0.69	-	-	-
4-1/2 x 7/8	100	25	5710-210	0.51	-	-	-	-	-	-	-
4-1/2 x 7/8	120	25	5710-212	0.51	-	-	-	-	-	-	-
5 x 7/8	16	25	5710-251	0.84	-	-	-	-	-	-	-
5 x 7/8	24	25	5710-252	0.68	5710-462	0.96	6559-501	0.96	-	-	-
5 x 7/8	36	25	5710-253	0.65	5710-463	0.91	6559-503	0.92	-	-	-
5 x 7/8	50	25	5710-255	0.61	5710-465	0.84	6559-505*	0.74	-	-	-
5 x 7/8	60	25	5710-256	0.58	5710-466	0.81	6559-506	0.83	-	-	-
5 x 7/8	80	25	5710-258	0.56	5710-468	0.79	6559-507	0.81	-	-	-
5 x 7/8	100	25	5710-260	0.56	-	-	6559-508	0.80	-	-	-
5 x 7/8	120	25	5710-262	0.56	-	-	-	-	-	-	-
7 x 7/8	16	25	5710-301	1.37	-	-	6559-520	2.34	-	-	-
7 x 7/8	24	25	5710-302	1.19	-	-	6559-521	1.71	-	-	-
7 x 7/8	36	25	5710-303	1.14	-	-	6559-523	1.57	-	-	-
7 x 7/8	50	25	5710-305	1.11	5710-505	1.51	6559-525	1.54	5616-205	2.78	-
7 x 7/8	60	25	5710-306	1.09	5710-506	1.47	6559-526*	1.48	-	-	-
7 x 7/8	80	25	5710-308	1.06	5710-508	1.39	6559-527*	1.42	-	-	-
7 x 7/8	100	25	5710-310	1.06	-	-	6559-528*	1.39	-	-	-
7 x 7/8	120	25	5710-312	1.06	-	-	6559-529	1.39	-	-	-

† 3M™ brand replaces Standard Abrasives, which may be supplied until inventory is depleted.

\* Minimum order quantity: (1000)

## Spiralcool Standard Air-Cooled Backing Pads

Ideal for all sanding operations on metal, plastic, fiberglass, etc. Smooth face pads available upon request.



Supplied with 5/8-11 Arbor Hole, except the 4-1/2" which will be supplied with a 5/8" smooth bore. Other arbor holes available upon request.

SIZE	DENSITY	MAX. RPM	ORDER NO.	PRICE EACH
4"	Flexible	12,000	5710-600	\$12.80
4"	Medium	12,000	5710-601	12.80
4"	Rigid	12,000	5710-602	12.80
4-1/2"	Flexible	11,000	5710-612	12.80
4-1/2"	Medium	11,000	5710-613	12.80
4-1/2"	Rigid	11,000	5710-614	12.80
5"	Flexible	10,000	5710-624	14.50
5"	Medium	10,000	5710-625	14.50
5"	Rigid	10,000	5710-626	14.50
7"	Flexible	7,000	5710-636	21.80
7"	Medium	8,500	5710-637	21.80
7"	Rigid	8,500	5710-638	21.80
9"	Flexible	6,500	5710-648	26.05
9"	Medium	6,500	5710-649	26.05
9"	Rigid	6,500	5710-650	26.05



Nuts and wrenches do not come with pads. Must be ordered separately.

DESCRIPTION	ORDER NO.	PRICE EACH
#102 Nut; 5/8-11	5710-665	\$4.90
#103 Nut; 5/8-11 For 4" - 5" Pads	5710-666	4.90
3/8-24 - 5/8-11 Adapter	5710-660	7.85
7/16-20 - 5/8-11 Adapter	5710-661	7.85
Spanner Wrench	5710-670	4.90

# PSA Discs

## PSA Aluminum Oxide Resin Bond Cloth Discs

Abrasive cloth discs have a pressure sensitive adhesive backing making them easy to apply to a rubber disc holder. Protective liner speeds disc changing and protects adhesive from work dust. Resin bond discs are made with a heavy resin abrasive cloth, assuring long life, with fast stock removal.



2

IMPORT			
GRIT	ORDER NO.	PKG QTY	PRICE PER PKG
<b>1" DIAMETER</b>			
36	5711-103	100	\$14.40
40	5711-104	100	13.00
50	5711-105	100	12.90
60	5711-106	100	12.90
80	5711-108	100	12.90
100	5711-110	100	12.90
120	5711-120	100	12.90
<b>1-1/2" DIAMETER</b>			
36	5711-153	100	\$18.50
40	5711-154	100	17.65
50	5711-155	100	16.80
60	5711-156	100	16.80
80	5711-158	100	16.80
100	5711-160	100	16.80
120	5711-162	100	16.80
<b>2" DIAMETER</b>			
36	5711-203	100	\$34.20
40	5711-204	100	32.50
50	5711-205	100	31.00
60	5711-206	100	29.50
80	5711-208	100	28.15
100	5711-210	100	26.70
120	5711-212	100	26.70

2

IMPORT			
GRIT	ORDER NO.	PKG QTY	PRICE PER PKG
<b>3" DIAMETER</b>			
36	5711-253	100	\$49.10
40	5711-254	100	46.85
50	5711-255	100	43.70
60	5711-256	100	39.25
80	5711-258	100	39.10
100	5711-260	100	42.30
120	5711-262	100	37.15
<b>5" DIAMETER</b>			
36	5711-303	50	49.45
40	5711-304	50	46.60
50	5711-305	50	44.00
60	5711-306	50	39.15
80	5711-308	50	40.05
100	5711-310	50	40.15
120	5711-312	50	36.65
<b>6" DIAMETER</b>			
36	5711-353	50	\$75.35
40	5711-354	50	72.30
50	5711-355	50	73.90
60	5711-356	50	57.90
80	5711-358	50	56.60
100	5711-360	50	53.15
120	5711-362	50	53.15

2

IMPORT				STANDARD ABRASIVES		
GRIT	ORDER NO.	PKG QTY	PRICE PER PKG	ORDER NO.	PKG QTY	PRICE PER PKG
<b>8" DIAMETER</b>						
36	5711-453	50	\$127.65	-	-	-
40	5711-454	50	123.65	-	-	-
50	5711-455	50	113.75	-	-	-
60	5711-456	50	106.20	-	-	-
80	5711-458	50	96.25	-	-	-
100	5711-460	50	93.55	-	-	-
120	5711-462	50	93.55	-	-	-
<b>9" DIAMETER</b>						
36	5711-503	50	\$176.85	-	-	-
40	5711-504	50	170.10	-	-	-
50	5711-505	50	153.65	-	-	-
60	5711-506	50	138.80	-	-	-
80	5711-508	50	132.15	5620-508	50	\$198.50
100	5711-510	50	125.25	-	-	-
<b>12" DIAMETER</b>						
40	5711-604	25	\$147.10	-	-	-
50	5711-605	25	138.75	-	-	-
60	5711-606	25	119.10	-	-	-
80	5711-608	25	116.50	-	-	-
100	5711-610	25	110.60	5620-560	10	64.70
120	5711-612	25	110.60	5620-562	10	77.00

## PSA Abrasive Disc – Disc Rolls With Liner

Silicon Carbide Grain glue bond, "A" weight paper. Treated for load resistance, recommended for all grinding of metal, wood and fiberglass. With release paper liner and self storing dispenser. Trouble free, the most efficient disc/roll package available. No grit or dust contamination, great shelf life. Stearate coated.



2

5"				6"	
GRIT	PKG QTY	ORDER NO.	PRICE PER PKG	ORDER NO.	PRICE PER PKG
100	100	-	-	5712-410†	\$26.75
120	100	5712-312†	\$21.95	5712-412†	26.75
150	100	5712-315†	21.95	5712-415†	26.75
180	100	5712-318†	21.95	5712-418†	26.75
220	100	5712-322†	21.95	5712-422†	26.75
320	100	5712-332†	21.95	5712-432†	26.75

† Limited Quantities

## PSA Disc Holders – Optimum performance with PSA Discs



2

DIAM.	MAX. RPM	SHK	ORDER NO.	PRICE EACH
1	15,000	1/4	5642-192	\$10.90

# Quick Change Discs

Available in a Choice of Quick Change Locking Systems.

## A/O 2 Ply



- Ideal for flat or contoured surfaces
- Best for MRO grinding, deburring, & finishing on ferrous metals.

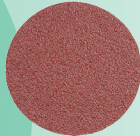

## A/O Extra 2-Ply



- Ideal for flat or contoured surfaces
- Good for difficult to grind metals, such as aircraft grade aluminum, High Nickel, Chrome Alloys, & heat-sensitive material.
- Includes grinding aid

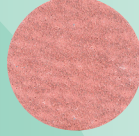

## Zirconia Pro 2-Ply

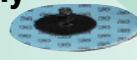

- Better choice for rapid stock removal on Stainless Steel, High Nickel Alloys, & Aluminum
- Features a grinding aid on a Y-weight backing
- Best performance under medium-to-heavy pressure

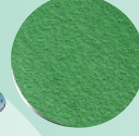

## Ceramic 2-Ply



- Best choice for rapid stock removal on Stainless Steel and High Nickel Alloys.
- Features a grinding aid for cooler operation
- Heavy pressure required

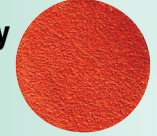

DIA.	GRIT	A/O 2 PLY				A/O EXTRA 2 PLY				ZIRCONIA PRO 2 PLY				CERAMIC 2 PLY			
		TS-STYLE ORDER NO.	TR-STYLE ORDER NO.	PKG QTY	PRICE PER PK.	TS-STYLE ORDER NO.	TR-STYLE ORDER NO.	PKG. QTY.	PRICE PER PK.	TS-STYLE ORDER NO.	TR-STYLE ORDER NO.	PKG. QTY.	PRICE PER PK.	TS-STYLE ORDER NO.	TR-STYLE ORDER NO.	PKG. QTY.	PRICE PER PK.
1"	36	5600-103	-	50	\$27.45	5601-603	-	50	\$29.21	-	-	-	-	-	-	-	-
	80	-	-	-	-	5601-608	-	50	25.52	-	-	-	-	-	-	-	-
	100	-	-	-	-	5601-610	-	50	25.52	-	-	-	-	-	-	-	-
	240	5600-124	-	50	23.36	-	-	-	-	-	-	-	-	-	-	-	-
1-1/2"	36	5600-153	-	50	\$32.74	-	-	-	-	-	-	-	-	5609-153	-	50	\$40.23
	40	5600-154	-	50	32.13	-	-	-	-	-	-	-	-	-	-	-	-
	50	5600-155	5600-655	50	32.13	-	-	-	-	5604-655	-	50	\$35.05	5609-155	-	50	39.68
	60	5600-156	5600-656	50	31.52	-	-	-	-	5604-656	5605-156	50	33.89	5609-156	-	50	38.02
	80	5600-158	-	50	31.52	5601-658	-	50	31.19	5604-658	5605-158	50	33.29	5609-158	-	50	36.81
	100	5600-160	-	50	31.52	5601-660	-	50	32.13	-	-	-	-	-	-	-	-
	120	5600-162	-	50	31.52	5601-662	-	50	32.13	5604-662	5605-162	50	33.29	5609-162	-	50	36.81
	180	5600-168	-	50	31.52	-	-	-	-	-	-	-	-	-	-	-	-
320	5600-182	-	50	31.52	-	-	-	-	-	-	-	-	-	-	-	-	
2"	24	5600-202	-	50	53.50	-	-	-	-	-	-	-	-	-	-	-	-
	36	5600-203	5600-703	50	50.70	-	-	-	-	5604-703	5605-203	50	57.00	5609-203	-	50	62.00
	40	5600-204	-	50	49.05	-	-	-	-	5604-704	-	50	53.50	-	-	-	-
	50	5600-205	5600-705	50	46.85	-	-	-	-	5604-705	-	50	51.41	5609-205	-	50	58.00
	60	5600-206	5600-706	50	44.97	5601-706	-	50	POA	5604-706	-	50	51.60	5609-206	-	50	56.50
	80	5600-208	5600-708	50	45.71	-	-	-	-	5604-708	5605-208	50	50.15	5609-208	-	50	56.50
	100	5600-210	-	50	44.42	-	-	-	-	-	-	-	-	5609-210	-	50	56.00
	120	5600-212	-	50	44.42	-	-	-	-	5604-712	-	50	49.60	5609-212	-	50	56.00
	240	5600-224	5600-724	50	44.42	-	-	-	-	-	-	-	-	-	-	-	-
	320	5600-232	5600-732	50	44.42	-	-	-	-	-	-	-	-	-	-	-	-
3"	36	5600-303	-	50	62.50	-	-	-	-	5604-803	5605-303	50	73.00	5609-303	5609-803	50	79.00
	40	-	-	-	-	-	-	-	-	5604-804	5605-304	50	68.50	-	-	-	-
	50	-	-	-	-	-	-	-	-	-	-	-	-	5609-305	5609-805	50	75.00
	60	-	-	-	-	-	-	-	-	-	-	-	-	-	-	-	-
	80	5600-308	5600-808	50	56.00	5601-808	-	50	58.00	-	-	-	-	5609-308	-	50	70.00
	100	5600-310	-	50	55.50	5601-810	-	50	57.00	-	-	-	-	-	-	-	-
120	5600-312	-	50	55.50	5601-812	-	50	55.50	-	-	-	-	-	-	-	-	

## Holder Pads

For All Quick Change Style Discs 12

Available for all small diameter Quick Change style discs, in soft, medium, and firm grades.



TS (SocAtt®)



TR (Lockit®)

SIZE	DEN-SITY	MAX. RPM	TS - TA4		TR - TA4	PRICE EACH
			ORDER NO.	ORDER NO.	ORDER NO.	
3/4"	Med.	40,000	5641-014	-	-	\$ 18.80
1"	Med.	40,000	5641-015	-	-	17.90
1-1/2"	Soft	20,000	5641-016	5641-059	-	21.66
1-1/2"	Med.	25,000	5641-017	5641-060	-	20.00
1-1/2"	Firm	30,000	5641-018	5641-061	-	22.43
2"	Soft	20,000	5641-019	5641-062	-	23.96
2"	Med.	25,000	5641-020	5641-063	-	22.99
2"	Firm	30,000	5641-021	5641-064	-	27.43

SIZE	DEN-SITY	MAX. RPM	TS - TA4		TR - TA4	PRICE EACH
			ORDER NO.	ORDER NO.	ORDER NO.	
3"	Soft	12,000	5641-022	5641-065	-	\$29.24
3"	Med.	20,000	5641-023	5641-066	-	26.59
3"	Firm	20,000	5641-024	5641-067	-	31.68
<b>5/8-11" ARBOR - LARGE DIAMETER, HARD FACE - TS HOLDER PADS</b>						
4-1/2"	Med.	18,000	5641-160	Low Profile	-	62.58
4-1/2"	Med.	18,000	5641-150	-	-	62.58

# Flap Wheels

Perfect tool for deburring, blending, finishing and cleaning inside and outside diameters of ferrous and non-ferrous materials.

**Buy Std. Ctn. Deduct 10%**

## Mounted Flap Wheels (1"–3" Diameters) Aluminum Oxide Resin Bond

\* Permanently affixed 1/4" or 1/4-20 threaded steel shank allows choice of best system for your tooling, and fast wheel changes. Affixed mandrel for concentricity and reduced chatter; less operator fatigue.

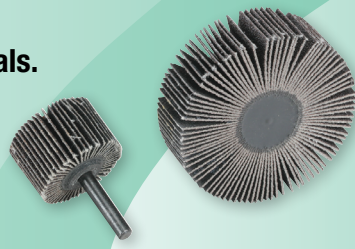

SIZE	GRIT	STD. CTN.	1/4" SHANK				1/4-20 SHANK					
			IMPORT		Weiber TIGER		USA STANDARD ABRASIVES		Weiber TIGER		USA STANDARD ABRASIVES	
			ORDER NO.	PRICE	ORDER NO.	PRICE	ORDER NO.	PRICE	ORDER NO.	PRICE	ORDER NO.	PRICE
1" x 1"	60	10	5714-156	\$2.02	6552-003	\$4.53	5615-006	\$7.66	6552-601	\$4.58	5615-136	\$8.59
	80	10	5714-158	2.02	6552-004	4.53	5615-008	7.66	6552-603	4.58	5615-138	8.59
	120	10	5714-162	2.02	6552-005	4.53	5615-012	7.88	6552-605	4.58	5615-142	8.59
1-1/2" x 1"	60	10	5714-406	2.49	6552-009	5.89	5615-026	9.03	-	-	5615-156	10.05
	80	10	5714-408	2.49	6552-010	5.89	5615-028	9.03	-	-	-	-
	120	10	5714-412	2.49	6552-011	5.89	5615-032	9.03	-	-	5615-162	10.05
2" x 1"	60	10	5714-556	2.93	6552-015	6.58	5615-056	11.46	6552-611	6.36	5615-186	11.58
	80	10	5714-558	2.93	6552-016	6.58	5615-058	11.46	6552-613	6.36	5615-188	11.58
	120	10	5714-562	2.97	6552-017	6.58	5615-062	11.46	-	-	5615-192	12.61
2-1/2" x 1"	60	10	5714-706	4.12	6552-486	6.87	5615-076	13.80	-	-	-	-
	80	10	5714-708	4.12	6552-487	6.87	5615-078	13.80	-	-	5615-208	14.23
	120	10	5714-712	4.19	-	-	5615-082	13.80	-	-	-	-
3" x 1"	60	10	5714-906	4.56	6552-027	8.68	5615-106	14.03	6552-621	9.21	5615-236	14.07
	80	10	5714-908	4.56	6552-028	8.68	5615-108	14.03	6552-623	9.21	5615-238	14.07
	120	10	5714-912	4.79	6552-029	8.68	5615-112	14.03	-	-	5615-242	15.31

† Limited Quantities

## Mounted Flap Wheel Drive Arbor



THREAD SIZE	ADAPTED SIZE	ORDER NO.	PRICE EACH
1/4-20	1/4"	5642-100	\$12.75

## Large Flap Wheels (4"–6" Diameters) Aluminum Oxide Resin Bond

Best Flap Wheel for applications requiring high stock removal. Provides maximum stability and smaller contact areas on work surface. Highest initial cut rate.



SIZE	GRIT	STD. CTN.	IMPORT				Weiber TIGER	
			ORDER NO.	PRICE	ORDER NO.	PRICE		
4" x 1" x 5/8"	60	1	5716-156	\$13.95	-	-	-	
	80	1	5716-158	14.20	6553-167†	\$19.84	-	
	120	1	5716-162	15.00	6553-169†	21.16	-	
6" x 1" x 1"	60	1	5716-356	22.20	6553-286	42.82	-	
	80	1	5716-358	22.85	6553-287	45.80	-	
	120	1	5716-362	23.75	6553-289†	36.95	-	
6" x 2" x 1"	60	1	5716-456	33.35	6553-326	71.29	-	
	80	1	5716-458	34.15	6553-327	76.07	-	
	120	1	5716-462	36.85	-	-	-	

† Limited Quantities

## Buff & Blend Combi Wheels

Wheels are constructed with alternating flaps of Buff & Blend and coated abrasive material. High rate of cut, while providing a uniform scratch pattern.

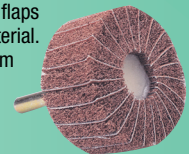

SIZE	GRIT	STD. CTN.	USA STANDARD ABRASIVES	
			ORDER NO.	PRICE
2" x 1" x 1/4"	60	10	5650-788	\$19.81
	80	10	5650-789	19.81
	120	10	5650-790	19.81
3" x 1" x 1/4"	60	10	5650-792	24.02
	80	10	5650-793	24.02
	120	10	5650-794	24.02
3" x 2" x 1/4"	60	5	5650-796	35.72
	80	5	5650-797	35.72
	120	5	5650-798	35.72
	180	5	5650-799	35.72

## Unmounted Flap Wheel Reducer Bushings

(Used in Pairs)

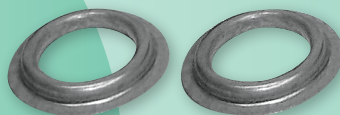

SIZE	ORDER NO.	PRICE/PAIR
1 to 1/2	6503-833	\$4.53
1 to 5/8	6503-834	4.53
1 to 3/4	6503-835	4.53

# Shop Rolls & Sanding Belts

## Cloth Shop Rolls – Aluminum Oxide

\* For Quick Stock Removal in Metal Finishing and Polishing Applications

\* Ability to Tear Desired Amount Eliminates Waste

2

3

IMPORT				SA STANDARD ABRASIVES™	
SIZE	GRIT	ORDER NO.	PRICE	ORDER NO.	PRICE
1"	50	—	—	5621-005	\$43.65
1"	60	5700-006	\$12.05	5621-006	40.92
1"	80	5700-008	11.50	5621-008	33.9
1"	100	5700-010	11.20	5621-010	33.41
1"	120	5700-012	11.20	5621-012	33.41
1"	150	5700-015	11.20	5621-015	33.41
1"	180	5700-018	11.20	5621-018	33.41
1"	220	5700-022	11.20	—	—
1"	240	5700-024	11.20	5621-024	33.41
1"	320	5700-032	11.20	5621-032	33.41
1-1/2"	50	—	—	5621-105	60.97
1-1/2"	60	5700-106	17.30	5621-106	57.61
1-1/2"	80	5700-108	16.45	5621-108	47.51
1-1/2"	100	5700-110	16.15	5621-110	45.76
1-1/2"	120	5700-112	16.15	5621-112	45.76
1-1/2"	150	5700-115	16.15	5621-115	45.76
1-1/2"	180	5700-118	16.15	5621-118	45.76
1-1/2"	220	5700-122	16.15	—	—
1-1/2"	240	5700-124	16.15	5621-124	45.76
1-1/2"	320	5700-132	16.15	5621-132	45.76
2"	50	—	—	5621-205	78.77
2"	60	5700-206	22.65	5621-206	72.84
2"	80	5700-208	21.60	5621-208	61.08
2"	100	5700-210	20.90	5621-210	58.10
2"	120	5700-212	20.90	5621-212	58.10
2"	150	5700-215	20.90	5621-215	58.10
2"	180	5700-218	20.90	5621-218	58.10
2"	220	5700-222	20.90	—	—
2"	240	5700-224	20.90	5621-224	58.10
2"	320	5700-232	20.90	5621-232	58.10



## Cloth Sanding Belts – Aluminum Oxide

2

GRIT	PKG QTY	1 x 42"		2 x 48"		3 x 21"		3 x 24"		4 x 24"	
		ORDER NO.	PRICE PER PKG	ORDER NO.	PRICE PER PKG	ORDER NO.	PRICE PER PKG	ORDER NO.	PRICE PER PKG	ORDER NO.	PRICE PER PKG
40	10	5701-754	\$12.20	5702-754	\$21.45	5703-754	\$17.30	5703-854	\$18.90	5704-604	\$28.55
50	10	5701-755	11.75	5702-755	20.80	5703-755	16.90	5703-855	18.55	5704-605	27.45
60	10	5701-756	11.25	5702-756	20.05	5703-756	16.40	5703-856	18.30	5704-606	27.05
80	10	5701-758	10.40	5702-758	17.60	5703-758	15.40	5703-858	17.80	5704-608	25.50
100	10	5701-760	10.05	5702-760	17.10	5703-760	14.25	5703-860	16.95	5704-610	24.20
120	10	5701-762	10.05	5702-762	17.10	5703-762	14.25	5703-862	16.95	5704-612	24.20
150	10	—	—	—	—	—	—	—	—	5704-615†	21.95
180	10	—	—	—	—	—	—	—	—	5704-618†	21.95

† Limited Quantities

\* X-Weight

\* Resin Bonded

\* Heavy Duty Construction

\* Ideal for sanding wood or metal

Other sizes and grits available upon request. Please inquire.

GRIT	PKG QTY	4 x 36"		6 x 48"	
		ORDER NO.	PRICE PER PKG	ORDER NO.	PRICE PER PKG
40	10	—	—	5705-654	\$61.85
50	10	5704-705	\$33.60	5705-655	59.85
60	10	5704-706	32.80	5705-656	58.55
80	10	5704-708	31.70	5705-658	55.85
100	10	5704-710	30.35	5705-660	54.10
120	10	5704-712	30.35	5705-662	54.10
150	5	5704-715†	13.80	5705-665†	24.60
180	5	5704-718†	13.80	—	—

† Limited Quantities



# Abrasive Sheets

## Quality Import



### Aluminum Oxide

#### 9" x 11" Cloth Sheets

- Resin Bonded
- Ideal for Sanding Wood or Metal
- Outlasts Paper by as much as 5 Times

GRIT	STD PKG	ORDER NO.	PRICE PER PKG
50	50	3273-050	\$37.00
60	50	3273-060	35.45
80	50	3273-080	34.75
100	50	3273-100	32.90
120	50	3273-120	32.90
150	50	3273-150	32.90
180	50	3273-180	32.90
220	50	3273-220	32.90
240	50	3273-240	32.90
320	50	3273-320	32.90
400	50	3273-400	32.90

### Silicon Carbide

#### 9" x 11" Waterproof Sheets

- Latex Impregnated Paper
- Offers Versatility of Wet or Dry Sanding

GRIT	STD PKG	ORDER NO.	PRICE PER PKG
100	50	3273-600	\$26.15
120	50	3273-605	26.15
150	50	3273-610	22.40
180	50	3273-615	18.85
220	50	3273-620	18.85
240	50	3273-625	18.85
280	50	3273-630	18.85
320	50	3273-635	18.85
400	50	3273-640	18.85
500	50	3273-645	18.85
600	50	3273-650	18.85
800	50	3273-655	18.85
1000	50	3273-660	18.85
1200	50	3273-665	18.85

### Emery

#### 9" x 11" Cloth Sheets

- Resin Bonded
- Ideal for Metal Finishing where Polishing is more important than Stock Removal

GRIT	STD PKG	ORDER NO.	PRICE PER PKG
Coarse	50	3273-500	\$35.45
Medium	50	3273-510	32.95
Fine	50	3273-520	32.95

### Crocus Cloth

#### 9" x 11" Sheets

- Resin Bonded
- Flexible cloth backing
- Used by machinists & mechanics for smoothing metal surfaces

GRIT	STD PKG	ORDER NO.	PRICE PER PKG
Fine	50	3273-700	\$47.15

### Silicon Carbide

#### 9" x 11" Sandscreen Sheets

- Unique Screen Mesh Prevents Loading
- Will Outlast Ordinary Sandpaper by as much as 10 Times
- Use Wet or Dry on Metal or Wood

GRIT	STD PKG	ORDER NO.	PRICE PER PKG
100	25	5718-010	\$40.80
120	25	5718-012	40.80
150	25	5718-015	40.80
220	25	5718-022	40.80

# Cartridge Rolls

## Straight Cartridge Rolls

Aluminum Oxide Resin Bond Cartridge Rolls feature a multi-layer, multi-wear design for long lasting durability. New abrasive cutting points are exposed throughout the life of the roll. Use for flash removal, polishing, removing machine tool marks, edge breaking, etc.



SIZE	GRIT	STD PKG	ORDER NO.	PRICE PER PKG	SIZE	GRIT	STD PKG	ORDER NO.	PRICE PER PKG	SIZE	GRIT	STD PKG	ORDER NO.	PRICE PER PKG
3/16 x 1 x 3/32	80	100	5618-001	\$39.69	3/8 x 1-1/2 x 1/8	40	100	5618-040	\$55.35	5/8 x 1-1/2 x 1/8	80	50	5618-080	\$50.47
3/16 x 1 x 3/32	100	100	5618-002	39.69	3/8 x 1-1/2 x 1/8	50	100	5618-041	55.35	5/8 x 1-1/2 x 3/16	60	50	5618-081	48.20
3/16 x 1 x 3/32	120	100	5618-003	42.09	3/8 x 1-1/2 x 1/8	60	100	5618-042	50.47	5/8 x 2 x 3/16	50	50	5618-084	56.00
3/16 x 1 x 3/32	180	100	5618-005	43.32	3/8 x 1-1/2 x 1/8	80	100	5618-043	55.35	5/8 x 2 x 3/16	60	50	5618-085	56.00
1/4 x 1 x 1/8	60	100	5618-008	39.69	3/8 x 1-1/2 x 1/8	100	100	5618-044	55.35	5/8 x 2 x 3/16	80	50	5618-086	59.50
1/4 x 1 x 1/8	80	100	5618-009	39.69	3/8 x 1-1/2 x 1/8	120	100	5618-045	55.35	3/4 x 1 x 1/8	80	50	5618-089	46.90
1/4 x 1 x 1/8	100	100	5618-010	42.09	3/8 x 1-1/2 x 1/8	180	100	5618-047	58.97	3/4 x 1 x 3/16	40	50	5618-090	45.08
1/4 x 1 x 1/8	120	100	5618-011	42.09	3/8 x 1-1/2 x 1/8	240	100	5618-048	58.97	3/4 x 1 x 3/16	80	50	5618-091	46.90
1/4 x 1 x 1/8	180	100	5618-012	43.32	3/8 x 2 x 1/8	60	100	5618-050	61.24	3/4 x 1-1/2 x 1/8	60	50	5618-092	57.00
1/4 x 1 x 1/8	240	100	5618-013	44.45	3/8 x 2 x 1/8	80	100	5618-051	66.12	3/4 x 1-1/2 x 1/8	80	50	5618-093	58.00
1/4 x 1 x 1/8	320	100	5618-014	44.45	3/8 x 2 x 1/8	100	100	5618-052	66.12	3/4 x 1-1/2 x 3/16	60	50	5618-095	57.00
1/4 x 1-1/2 x 1/8	60	100	5618-015	46.84	3/8 x 2 x 1/8	120	100	5618-053	67.37	3/4 x 1-1/2 x 3/16	80	50	5618-096	56.00
1/4 x 1-1/2 x 1/8	80	100	5618-016	48.09	1/2 x 1 x 1/8	60	100	5618-055	48.09	3/4 x 1-1/2 x 3/16	120	50	5618-097	57.00
1/4 x 1-1/2 x 1/8	100	100	5618-017	49.34	1/2 x 1 x 1/8	80	100	5618-056	49.34	3/4 x 1-1/2 x 1/4	60	50	5618-098	57.00
1/4 x 1-1/2 x 1/8	120	100	5618-018	48.09	1/2 x 1 x 1/8	100	100	5618-057	50.47	3/4 x 1-1/2 x 1/4	80	50	5618-099	58.00
1/4 x 1-1/2 x 1/8	150	100	5618-019	50.47	1/2 x 1 x 1/8	120	100	5618-058	50.47	3/4 x 1-1/2 x 1/4	120	50	5618-100	59.00
1/4 x 1-1/2 x 1/8	180	100	5618-020	50.47	1/2 x 1-1/2 x 1/8	36	100	5618-060	72.12	3/4 x 2 x 3/16	40	50	5618-102	73.00
1/4 x 1-1/2 x 1/8	320	100	5618-021	50.47	1/2 x 1-1/2 x 1/8	40	100	5618-061	70.89	3/4 x 2 x 3/16	60	25	5618-103	36.50
1/4 x 1-1/2 x 1/8	400	100	5618-022	55.35	1/2 x 1-1/2 x 1/8	50	100	5618-062	70.89	3/4 x 2 x 3/16	80	25	5618-104	38.00
1/4 x 2 x 1/8	80	100	5618-023	60.10	1/2 x 1-1/2 x 1/8	60	100	5618-063	67.37	3/4 x 2 x 3/16	100	50	5618-105	78.00
1/4 x 2 x 1/8	100	100	5618-024	60.10	1/2 x 1-1/2 x 1/8	80	100	5618-064	69.74	3/4 x 2 x 3/16	120	25	5618-106	38.00
1/4 x 2 x 1/8	120	100	5618-025	61.24	1/2 x 1-1/2 x 1/8	100	100	5618-065	70.89	3/4 x 2 x 1/4	60	25	5618-107	36.50
5/16 x 1-1/2 x 1/8	80	100	5618-030	55.35	1/2 x 1-1/2 x 1/8	120	100	5618-066	67.37	3/4 x 2 x 1/4	80	25	5618-108	39.25
5/16 x 1-1/2 x 1/8	100	100	5618-031	57.84	1/2 x 1-1/2 x 1/8	180	100	5618-067	70.89	3/4 x 2 x 1/4	120	25	5618-110	39.25
5/16 x 1-1/2 x 1/8	120	100	5618-032	58.97	1/2 x 1-1/2 x 1/8	240	100	5618-069	75.75	1 x 1-1/2 x 1/4	60	50	5618-111	98.50
3/8 x 1 x 1/8	60	100	5618-034	44.45	1/2 x 2 x 1/8	60	50	5618-071	40.83	1 x 1-1/2 x 1/4	80	25	5618-112	51.00
3/8 x 1 x 1/8	80	100	5618-035	44.45	1/2 x 2 x 1/8	80	50	5618-072	42.07	1 x 2 x 1/4	60	25	5618-113	61.00
3/8 x 1 x 1/8	100	100	5618-036	44.45	1/2 x 2 x 1/8	120	50	5618-074	42.07	1 x 2 x 1/4	80	25	5618-114	63.00
3/8 x 1 x 1/8	120	100	5618-037	44.45	1/2 x 2 x 3/16	60	50	5618-075	40.83					
3/8 x 1 x 1/8	180	100	5618-038	46.84	1/2 x 2 x 3/16	100	50	5618-077	42.07					
3/8 x 1 x 1/8	240	100	5618-039	46.84										



# Cartridge Rolls

## Full Taper Cartridge Rolls



SIZE	GRIT	STD PKG	ORDER NO.	PRICE PER PKG
3/8 x 1 x 1/8	60	100	5618-300	\$80.52
3/8 x 1 x 1/8	80	100	5618-301	84.14
3/8 x 1 x 1/8	120	100	5618-302	84.14
3/8 x 1 x 1/8	180	100	5618-303	84.14
3/8 x 1-1/2 x 1/8	60	100	5618-305	92.54
3/8 x 1-1/2 x 1/8	80	100	5618-306	90.15
3/8 x 1-1/2 x 1/8	120	100	5618-307	90.15

SIZE	GRIT	STD PKG	ORDER NO.	PRICE PER PKG
1/2 x 1-1/2 x 1/8	36	100	5618-312	\$98.67
1/2 x 1-1/2 x 1/8	60	100	5618-314	93.79
1/2 x 1-1/2 x 1/8	80	100	5618-315	94.94
1/2 x 1-1/2 x 1/8	100	100	5618-316	96.40
1/2 x 1-1/2 x 1/8	120	100	5618-317	94.94
1/2 x 1-1/2 x 1/8	180	100	5618-318	98.67

SIZE	GRIT	STD PKG	ORDER NO.	PRICE PER PKG
1/2 x 2 x 1/8	60	50	5618-319	\$51.04
1/2 x 2 x 1/8	80	50	5618-320	51.60
1/2 x 2 x 1/8	180	50	5618-321	53.50
3/4 x 1-1/2 x 1/8	80	50	5618-324	66.00
3/4 x 1-1/2 x 3/16	80	50	5618-327	66.00

# Mandrels For Cartridge Rolls

- Cartridge Rolls of 3/4" length – 1/2" Pilot Length
- Cartridge Rolls of 1" length – 3/4" Pilot Length
- Cartridge Rolls of 1-1/2" length – 1" Pilot Length
- Cartridge Rolls of 2" length – 1-1/2" Pilot Length
- Cartridge Rolls of 2-1/2" length – 2" Pilot Length

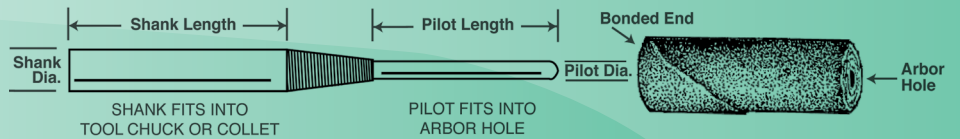

DESCRIPTION	PILOT DIA.	PILOT LGTH	SHANK DIA.	SHANK LGTH	O/A LGTH	ORDER NO.	PRICE EACH
CM-2B	3/32	3/4	1/8	1	2-3/4	5642-150	\$5.26
CM-2E	3/32	3/4	1/4	1	2-3/4	5642-152	5.95
CM-2F	3/32	1	1/4	1-1/4	3	5642-153	5.95
CM-3	1/8	1/2	1/8	1	2-1/2	5642-154	5.26
CM-4	1/8	3/4	1/8	1	2-3/4	5642-155	5.26
CM-5	1/8	1	1/8	1	2-1/2	5642-156	5.26
CM-6	1/8	1-1/2	1/8	1	3-1/2	5642-157	5.95
CM-7	1/8	1/2	1/4	1-1/4	2-1/4	5642-158	5.95
CM-8	1/8	3/4	1/4	1-1/4	2-1/2	5642-159	5.95
CM-9	1/8	1	1/4	1-1/4	2-3/4	5642-160	5.08

DESCRIPTION	PILOT DIA.	PILOT LGTH	SHANK DIA.	SHANK LGTH	O/A LGTH	ORDER NO.	PRICE EACH
CM-10	1/8	1-1/2	1/4	1-1/4	3-1/4	5642-161	\$5.08
CM-11	1/8	2	1/4	1-1/4	4	5642-162	6.46
CM-15	3/16	3/4	1/4	1-1/4	2-1/2	5642-163	5.95
CM-16	3/16	1	1/4	1-1/4	2-1/2	5642-164	5.95
CM-17	3/16	1-1/2	1/4	1-1/4	3-3/8	5642-165	6.77
CM-18	3/16	2	1/4	1-1/4	4	5642-166	6.77
CM-21	1/4	1	1/4	1-1/4	3	5642-168	5.95
CM-22	1/4	1-1/2	1/4	1-1/4	3-1/2	5642-169	6.77
CM-23	1/4	2	1/4	1-1/4	4	5642-170	6.77

# Non-Woven Abrasives



## Surface Conditioning Discs Quick Change Discs, Aluminum Oxide (A/O), FE

Type "FE" material is very flexible, with high edge durability. FE provides a high initial and extended rate of cut. Performs well on flat and contoured surfaces. Ideal on a variety of deburring, blending and cleaning applications.



SIZE	GRIT	MAX. RPM	TS-STYLE	TR-STYLE	HOOK & LOOP		PKG QTY	PRICE PER PKG
			ORDER NO.	ORDER NO.	MAX. RPM	ORDER NO.		
1-1/2"	Coarse	12,000 - 20,000	5650-106	5650-130	-	-	50	\$56.56
1-1/2"	Medium	12,000 - 20,000	5650-107	5650-131	-	-	50	56.56
2"	Coarse	12,000 - 20,000	5650-109	5650-133	-	-	50	82.55
2"	Medium	12,000 - 20,000	5650-110	5650-134	-	-	50	82.55
2"	Very Fine	12,000 - 20,000	5650-111	5650-135	-	-	50	82.55
3"	Coarse	10,000 - 18,000	5650-112	5650-136	-	-	25	78.72
3"	Medium	10,000 - 18,000	5650-113	5650-137	-	-	25	78.72
3"	Very Fine	10,000 - 18,000	5650-114	5650-138	-	-	25	78.72
4-1/2"	Coarse	-	-	-	6,000 - 8,000	5650-256	10	52.69
4-1/2"	Very Fine	-	-	-	6,000 - 8,000	5650-258	10	45.96
5"	Coarse	-	-	-	5,000 - 7,000	5650-259	10	63.39
5"	Medium	-	-	-	5,000 - 7,000	5650-260	10	54.83
5"	Very Fine	-	-	-	5,000 - 7,000	5650-261	10	54.83
7"	Coarse	-	-	-	3,000 - 6,000	5650-262	10	107.81

Type "GP" Surface Conditioning Discs are also available upon request. Call for delivery. Not as flexible as Type "FE", works especially well on flat surfaces.

## Holder Pads For Hook & Loop Style Discs

SIZE	MAX. RPM	ORDER NO.	PRICE EACH
4-1/2" with 5/8-11	10,000	5642-502	\$48.51
5" with 5/8-11	10,000	5642-503	48.51
7" with 5/8-11	6,000	5642-504	56.95

## High Strength Buff & Blend Discs With Center Hole, Aluminum Oxide (A/O)

The best product for finishing and light deburring applications. A very conformable and durable tool for finishing and polishing applications on metals, plastics and glass.



## Holder Pads For All Quick Change Style Discs

Available for all small diameter Quick Change style discs, in soft, medium and firm grades.

SIZE	DENSITY	MAX. RPM	TS-STYLE w/TA4	TR-STYLE w/TA4	PRICE EACH
			ORDER NO.	ORDER NO.	
3/4"	Medium	40,000	5641-014	-	\$ 18.80
1"	Medium	40,000	5641-015	-	17.90
1-1/2"	Soft	20,000	5641-016	5641-059	21.66
1-1/2"	Medium	25,000	5641-017	5641-060	20.00
1-1/2"	Firm	30,000	5641-018	5641-061	22.43
2"	Soft	20,000	5641-019	5641-062	23.96
2"	Medium	25,000	5641-020	5641-063	22.99
2"	Firm	30,000	5641-021	5641-064	27.43
3"	Soft	12,000	5641-022	5641-065	29.24
3"	Medium	20,000	5641-023	5641-066	26.59
3"	Firm	20,000	5641-024	5641-067	31.68



TS (SocAtt®)



TR (Lockit®)

SIZE	HOLE	GRADE	MAX. RPM	PKG QTY	ORDER NO.	PRICE PER PKG
6"	1/2"	Very Fine	3,600	10	5650-671	\$41.38
8"	1/2"	Very Fine	2,700	10	5650-673	67.97
10"	1/2"	Very Fine	2,000	10	5650-674	94.06

## Buff & Blend Discs

### Buff & Blend Quick Change "GP" Discs, Aluminum Oxide (A/O)

Flexible, conformable discs constructed of GP material, which provides a high rate of cut while producing consistent finishes. Applications include blending, cleaning, deburring and finishing.

SIZE	GRIT	MAX. RPM	PKG QTY	TS-STYLE	TR-STYLE	PRICE PER PKG
				ORDER NO.	ORDER NO.	
1-1/2"	Medium	12,000	50	5650-506	-	\$69.80
1-1/2"	Fine	12,000	50	5650-507	-	67.77
2"	Medium	12,000	50	5650-509	5650-539	74.90
2"	Fine	12,000	50	5650-510	5650-540	71.34
2"	Very Fine	12,000	50	5650-511	5650-541	71.34
3"	Medium	8,000	25	5650-512	5650-542	60.89
3"	Fine	8,000	25	5650-513	5650-543	55.28
3"	Very Fine	8,000	25	5650-514	-	-

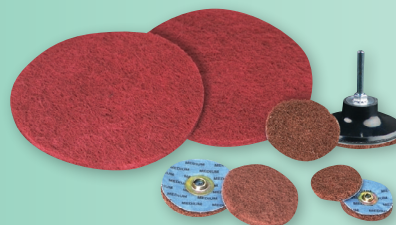

TS (SocAtt®)

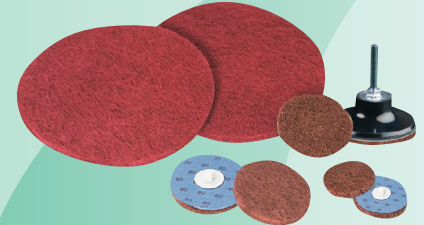

TR (Lockit®)

# Non-Woven Abrasives



## Type 27 Unitized Discs

Manufactured from the highest quality Unitized material. Unique design offers material removal while imparting a final finish. Used in conjunction with, and sometimes in lieu of, a coated abrasive Resin Fibre Disc or Flap Disc.

- Deburring
- Edge Breaking
- Blending
- Cleaning
- Final Polishing

500	Soft Density - Finishing & Polishing
600	Medium Density - Blending & Polishing
700	Medium Density - Deburring & Cleaning
800	Hard Density - Deburring

**Buy  
Std. Ctn.  
Deduct  
10%\***

\*excluding accessories



SIZE	SERIES	STD. CTN.	ORDER NO.	PRICE EACH
4-1/2 x 7/8	532	5	5651-130	\$29.83
4-1/2 x 7/8	632	5	5651-131	32.6
4-1/2 x 7/8	732	5	5651-132	34.05
4-1/2 x 7/8	821	5	5651-135	38.89
4-1/2 x 7/8	811	5	5651-133	38.89

1

## Quick Change Surface Conditioning Discs

Use on Die Grinders for deburring, blending, finishing, cleaning and polishing. Suitable for a wide variety of light fabrication, repair and for stainless steel, and ferrous & non-ferrous metals.



Roll On style, (R-Hub) shown



4

CGW			ALUMINUM OXIDE			
DIAM.	GRIT	RPM	PKG. QTY.	ROLL ON (R HUB) ORDER NO.	TURN ON (S HUB) ORDER NO.	PRICE PER PACK
2"	Coarse	25,000	50	5723-300	5723-320	\$55.17
	Medium	25,000	50	5723-301	5723-321	55.17
	A Very Fine	25,000	50	5723-302	5723-322	55.17
3"	Coarse	20,000	25	5723-305	5723-325	52.84
	Medium	20,000	25	5723-306	5723-326	52.84
	A Very Fine	20,000	25	5723-307	-	52.84

# Non-Woven Abrasives

## Convolute Wheels

Convolute Wheels are constructed by wrapping non-woven nylon, impregnated throughout with abrasive grain, around a hard core.

## GP Plus Wheels

Removes medium to heavy burrs and edge breaking.

SIZE	GRAIN	SPEC.	GRADE	MAX. RPM	ORDER MULTIPLE	ORDER NO.	PRICE EACH
6 x 1/2 x 1	S/C	8SF	Fine	6,000	4	5651-880	\$ 74.04
6 x 1/2 x 1	S/C	8SM	Medium	6,000	4	5651-882	74.90
6 x 1/2 x 1	S/C	9SF	Fine	6,000	4	5651-881	74.04
6 x 1 x 1	S/C	8SF	Fine	6,000	3	5651-884	103.64
6 x 1 x 1	S/C	8SM	Medium	6,000	3	5651-887	104.86
6 x 1 x 1	S/C	9SF	Fine	6,000	3	5651-885	103.64
6 x 2 x 1	S/C	9SF	Fine	6,000	2	5651-888	184.58
8 x 1/2 x 3	S/C	8SF	Fine	4,500	4	5651-892	88.08
8 x 1/2 x 3	S/C	9SF	Fine	4,500	4	5651-893	88.08
8 x 1 x 3	S/C	8SF	Fine	4,500	3	5651-896	129.63
8 x 1 x 3	S/C	8SM	Medium	4,500	3	5651-894	131.09
8 x 1 x 3	S/C	9SF	Fine	4,500	3	5651-897	129.63
8 x 2 x 3	S/C	8SF	Fine	4,500	2	5651-900	226.02
8 x 2 x 3	S/C	8SM	Medium	4,500	2	5651-901	228.65
12 x 1/2 x 5	S/C	8SF	Fine	3,000	5	5651-904	124.27
12 x 1 x 5	S/C	8SF	Fine	3,000	2	5651-908	203.37
12 x 1 x 5	S/C	9SF	Fine	3,000	2	5651-909	203.37
12 x 2 x 5	S/C	8SF	Fine	3,000	-	5651-912	361.51
12 x 2 x 5	S/C	9SF	Fine	3,000	-	5651-913	361.51

## LDW (Light Deburring Wheels)

Removes light burrs; use prior to polishing.

SIZE	GRAIN	SPEC.	GRADE	MAX. RPM	ORDER MULTIPLE	ORDER NO.	PRICE EACH
6 x 1/2 x 1	S/C	6SF	Fine	6,000	4	5651-920	\$ 75.08
6 x 1/2 x 1	S/C	7SF	Fine	6,000	4	5651-921	80.08
6 x 1/2 x 1	S/C	8SF	Fine	6,000	4	5651-922	80.08
6 x 1 x 1	S/C	6SF	Fine	6,000	3	5651-926	105.10
#6 x 1 x 1	S/C	7SF	Fine	6,000	3	5651-927	112.12
6 x 1 x 1	S/C	8SF	Fine	6,000	3	5651-928	112.12
8 x 1/2 x 3	S/C	8SF	Fine	4,500	4	5651-934	95.28
8 x 1 x 3	S/C	7SF	Fine	4,500	3	5651-939	140.24
8 x 1 x 3	S/C	8SF	Fine	4,500	3	5651-940	140.24
12 x 1/2 x 5	S/C	7SF	Fine	3,000	5	5651-945	123.20
12 x 1/2 x 5	S/C	8SF	Fine	3,000	5	5651-946	123.20
12 x 1 x 5	S/C	7SF	Fine	3,000	2	5651-951	201.57
12 x 1 x 5	S/C	8SF	Fine	3,000	2	5651-952	201.57
12 x 2 x 5	S/C	8SF	Fine	3,000	-	5651-958	358.37

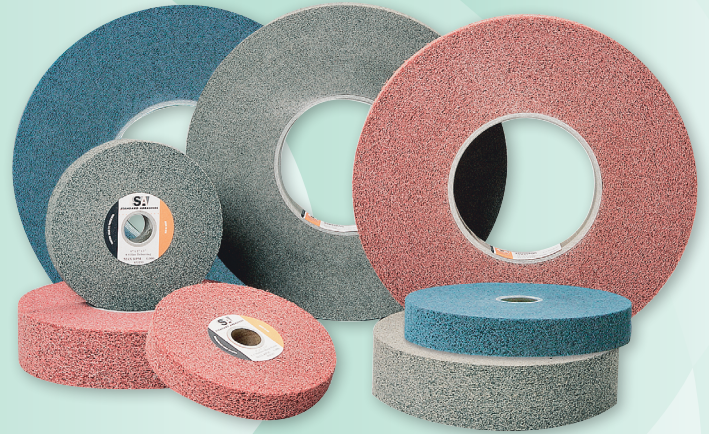

## Deburring Wheels

Excellent starting point for medium to heavy deburring and polishing.

SIZE	DENSITY	GRAIN	GRADE	MAX. RPM	ORDER MULTIPLE	ORDER NO.	PRICE EACH
6 x 1/2 x 1	Medium	S/C	Fine	6,000	4	5651-002	\$74.90
6 x 1/2 x 1	Hard	S/C	Fine	6,000	4	5651-003	74.90
6 x 1 x 1	Medium	S/C	Fine	6,000	3	5651-006	104.86
6 x 1 x 1	Hard	S/C	Fine	6,000	3	5651-007	104.86
6 x 2 x 1	Hard	S/C	Fine	6,000	2	5651-008	171.22
8 x 1/2 x 3	Hard	S/C	Fine	4,500	4	5651-010	89.10
8 x 1 x 3	Medium	S/C	Fine	4,500	3	5651-013	131.09
8 x 1 x 3	Hard	S/C	Fine	4,500	3	5651-014	131.09

# Non-Woven Abrasives



## Standard Abrasives - Unitized Mounted Points

Unitized Mounted Points are made from high durability material and are available in standard ANSI shapes for varying workpiece dimensions and applications.



### Series:

- 600 - High Durability, Medium density (Blending/Polishing)
- 700 - High Durability, Medium density (Deburring/Cleaning)
- 800 - High Durability, Hard density (Deburring/Cleaning)

### Size Chart:

A SHAPES							
SHAPE	MAX. RPM	SERIES	GRAIN	GRADE	ORDER MULTIPLE	ORDER NO.	PRICE EACH
A21	34,500	731	A/O	Fine	5	5651-502	\$20.99
A21	34,500	732	S/C	Fine	5	5651-503	20.99

SHAPE	SIZE
A21	1" x 1" x 1/4"
B52	3/8" x 3/4" x 1/8"
B90	1/2" x 1/2" x 1/8"
B121	1/2" x 1/2" x 1/8"

SHAPE	SIZE
W160	1/4" x 1/4" x 1/8"
W163	1/4" x 1/2" x 1/8"
W183	1/2" x 1/4" x 1/8"
W185	1/2" x 1/2" x 1/8"
W220	1" x 1" x 1/4"

B SHAPES							
SHAPE	MAX. RPM	SERIES	GRAIN	GRADE	ORDER MULTIPLE	ORDER NO.	PRICE EACH
B52	45,300	731	A/O	Fine	5	5651-508	\$8.51
B52	45,300	732	S/C	Fine	5	5651-509	8.51
B52	45,300	811	A/O	Coarse	5	5651-510	8.91
B90	34,500	731	A/O	Fine	5	5651-512	6.77
B90	34,500	732	S/C	Fine	5	5651-513	6.77
B121	45,300	731	A/O	Fine	5	5651-516	7.37
B121	45,300	811	A/O	Coarse	5	5651-517	8.07
B121	45,300	821	A/O	Medium	5	5651-518	8.07

W SHAPES							
SHAPE	MAX. RPM	SERIES	GRAIN	GRADE	ORDER MULTIPLE	ORDER NO.	PRICE EACH
W160	81,300	821	A/O	Medium	5	5651-520	\$4.55
W163	60,000	821	A/O	Medium	5	5651-522	5.36
W183	51,700	632	S/C	Fine	5	5651-523	5.15
W183	51,700	811	A/O	Coarse	5	5651-526	5.88
W183	51,700	821	A/O	Medium	5	5651-527	5.88
W185	34,500	631	A/O	Fine	5	5651-528	6.39
W185	34,500	632	S/C	Fine	5	5651-529	6.39
W185	34,500	731	A/O	Fine	5	5651-530	6.76
W185	34,500	732	S/C	Fine	5	5651-531	6.76
W185	34,500	811	A/O	Coarse	5	5651-532	7.44
W185	34,500	821	A/O	Medium	5	5651-533	7.44
W220	25,000	811	A/O	Coarse	5	5651-534	20.43

## 6" x 9" Hand Pads

Hand Pads are flexible, washable, and conform to workpiece. Ideal for hand applications on metals, composite or plastic surfaces. Use for cleaning, finishing or polishing. Color coded.



## Hand Pad Holder

For use with 3" x 6" pads

Order No. 5642-520

Price each..... \$29.87

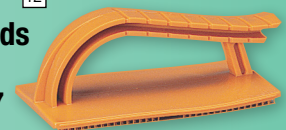

COLOR CODE	APPLICATION	IMPORT			TIGER			STANDARD ABRASIVES		
		ORDER NO.	PKG QTY	PRICE PER PKG	ORDER NO.	PKG QTY	PRICE PER PKG	ORDER NO.	PKG QTY	PRICE PER PKG
White	Non-Abrasive Pad For Polishing and Light Cleaning	5718-100	10	\$8.10	-	-	-	5651-700	60	\$88.47
Grey	Ultra-Fine S/C Abrasive Pad For Free Hand Cleaning & Finishing Usable with mild detergents	5718-105	10	8.10	6551-434	60	\$101.84	5651-705	60	87.00
Maroon	General Purpose A/O Abrasive Pad For Basic Cleaning and Finishing Usable with most solvents	5718-110	10	8.95	6551-444	60	103.50	5651-710	60	87.00
Tan	Heavy Duty A/O Abrasive Pad For Heavy Duty Cleaning or Fast Action Finishing Usable with most solvents	5718-120	10	16.15	6551-460	60	78.25	5651-720	40	145.94
					6551-454	40	164.77			

## Scouring Hand Pads

Green	Industrial	5718-115	10	8.10	-	-	-	5651-715	60	90.28
Green	Commercial (Food Processing)	-	-	-	6551-457	60	81.14	-	-	-